

**UNIVERSITY OF EL SALVADOR  
SCHOOL OF ARTS AND SCIENCES  
DEPARTMENT OF FOREIGN LANGUAGES**



**TITLE:**

**IMPLEMENTATION OF TRANSLATION TECHNIQUES, USE OF SOFTWARE  
AND IMAGE EDITING IN LEGAL DOCUMENTS**

PRESENTED BY: CARNÉ  
KATERIN YESSENIA GÓMEZ JIMÉNEZ (GJ15002)  
MARLA YAMILETH TORRES ARGUETA (TA01016)  
NORMA MARICELA ARÉVALO RIVERA (AR15025)

**FINAL REPORT OF THE SPECIALIZATION COURSE:  
BASICS OF TRANSLATION**

**IN ORDER TO OBTAIN THE DEGREE OF:  
BACHELOR OF ARTS IN MODERN LANGUAGES WITH A MAJOR IN FRENCH  
AND ENGLISH**

**SPECIALIZATION PROFESSOR  
MAESTRA CLAUDIA ELIZABETH OSORIO CRUZ**

**GENERAL COORDINATOR OF THE GRADUATION PROCESS  
MAESTRO MIGUEL ÁNGEL CARRANZA CAMPOS**

**CIUDAD UNIVERSITARIA, DR. FABIO CASTILLO FIGUEROA, SAN  
SALVADOR, EL SALVADOR, CENTROAMÉRICA, NOVEMBER, 2022**

**AUTHORITIES OF THE UNIVERSITY OF EL SALVADOR**

**RECTOR**

MAESTRO ROGER ARMANDO ARIAS ALVARADO

**ACADEMIC VICE-RECTOR**

DOCTOR RAÚL ERNESTO AZCÚNAGA LÓPEZ

**ADMINISTRATIVE VICE-RECTOR**

INGENIERO JUAN ROSA QUINTANILLA QUINTANILLA

**GENERAL SECRETARY**

INGENIERO FRANCISCO ANTONIO ALARCÓN SANDOVAL

**AUTHORITIES OF THE SCHOOL OF ARTS AND SCIENCES**

**DEAN**

MAESTRO OSCAR WUILMAN HERRERA RAMOS

**VICE-DEAN**

MAESTRA SANDRA LORENA BENAVIDES DE SERRANO

**SECRETARY**

MAESTRO YUPILTSINCA ROSALES CASTRO

**AUTHORITIES OF THE DEPARTMENT OF FOREIGN LANGUAGES**

**HEAD OF THE FOREIGN LANGUAGES DEPARTMENT**

MAESTRA ANA GRACE GÓMEZ ALEGRÍA

**GENERAL COORDINATOR OF THE GRADUATION PROCESS**

MAESTRO MIGUEL ÁNGEL CARRANZA CAMPOS

**SPECIALIZATION PROFESSOR**

MAESTRA CLAUDIA ELIZABETH OSORIO CRUZ

# Index

<b>ABSTRACT</b> .....	4
<b>INTRODUCTION</b>	
Introduction .....	5
Argumentative text .....	6
<b>TRANSLATION PROCESS</b>	
Concept of translation process .....	8
Translation process .....	10
Translation process steps .....	11
<b>TRANSLATIONS</b>	
Digestive System .....	13
Operation manual mp5 player .....	19
Birth certificates .....	41
University Transcripts .....	43
University Diplomas .....	51
Marriage of divorce certificates .....	53
Protocol of agreement .....	55
<b>CONCLUSIONS</b>	
Argumentative essay .....	63
<b>RECOMMENDATIONS</b> .....	65
<b>REFERENCES</b> .....	67

## **ABSTRACT**

The translation process goes beyond the exchange of ideas from the source language to the target language. It requires a deep analysis of what is to be conveyed, the type of technique it is convenient to use, the purpose, and the audience it is addressed to. Each document has its own relevance, so each one must be treated professionally and with due respect toward its final recipient. Therefore, in this document we present a compilation of important translated documents, from English to Spanish and vice-versa, the ones we worked with throughout the specialization course, including, translated images, a birth, marriage, and divorce certificate, a university transcript, a diploma, and a protocol of agreement. We chose the right process of translation with seven important steps: reading the text, analysis, and research, translation, taking a break, comparing the two versions, editing and proofreading, and final review. In addition, the new era requires the use of different software such as Pixlr, Photopea, Cat tools that help to speed up long translation files and facilitates image editing. Despite being a complex job, it is gratifying to see the result of hours of work, and the ability we have now to transmit into our mother tongue those ideas that were originally written in a foreign language. A professional translator must be able to make the reader perceive the text as the original, not as a text that has undergone a process of transformation, a good translator is one who remains invisible to the reader's eyes.

Keywords: Translation; Process; Language; Software; Message.

## INTRODUCTION

### Introduction

Translation has become an essential part of our lives and transports us to cultures totally different from the ones we know. That is why a group of students of the bachelor's degree in "Lenguas Modernas: Especialidad en Francés e Inglés" at the University of El Salvador, considered it wise to choose "Fundamentals of Translation" as a field of specialization in the year 2022, which will create the basis for a future area of work. However, at the end of this interesting journey, it is important to demonstrate with facts, not just words the fruits of our efforts.

This portfolio is made to serve as a tool that allows us as future professionals to store evidence of our contributions and achievements throughout the course and in the same way reflect all our learning processes.

First, it contains the definition of translation according to our experiences and ideas. Also, it includes reliable sources that enrich our performance. Then, it shows the creation of our own process of translation with a brief description of each step that helps us to obtain better results at the end of our assignments.

In addition, it has a compilation of all those projects, activities, and evidence carried out during the 4 modules of the specialization course, such as the translation and edition of images, translation of operation manuals, birth, marriage, and divorce certificates, University transcripts and diplomas, and a protocol of agreement.

Finally, some conclusions on the practice of translation and certain recommendations for students of the foreign language department who will take "The Fundamentals of Translation" Specialization Course in the future. This portfolio collects the products of our efforts to learn and improve every day.

## Argumentative text:

### THE IMPORTANCE OF TRANSLATION

*“Translation is not a matter of words only: it is a matter of making intelligible a whole culture.”* Antony Burgues. Throughout the years, translation has played a fundamental role in history. It is used to expand the knowledge of many cultures all over the world. It started with the Rosetta stone, which was found in 196 BC in three different languages, Ancient Egyptian, Demotic, and Ancient Greek, to the present day with the translation of the Bible into approximately 631 languages.

Have you ever wondered how you can read the manual of your new cell phone, computer, TV, and other electronic devices when the manual was created in a foreign language? The translation can be found everywhere from your favorite book, movie, series, magazine, music, and website to cosmetics and personal care and hygiene products, but for us, it is so common to have information instantly that we forget who carried out this work. Translation is essential in our professional and daily life, otherwise, there would be ignorance of new studies and technological advances, and mainly, there would be a language barrier between people.

The importance of the translator's work in society is of great relevance because it could contribute to maintaining world peace. As we all know, translation is vital when transferring news from around the world, many times journalists have risked their lives to get all the information that they need. Now, imagine how difficult it could be to translate news coming from other countries, and present them to local bodies and regional centers. Otherwise, the news will be vague, incomprehensible, and unreliable. In terms of education, translation is a great way to spread knowledge and help to learn another language. We could not have the contribution of excellent leaders such as Jean Piaget (1896-1980), María Montessori (1870-1952), Howard Gardner (1943-), etc.

Furthermore, translation plays a leading role in the case of multinational or multicultural companies and organizations because, nowadays, Global businesses cannot sell their

products and services without translation. It is necessary to use data in a foreign language and negotiate terms with international governments, or other local companies where a proper translation of relevant proposals and agreements is required. Regarding the tourism industry, thanks to globalization, it has greatly expanded over the years. With more people than ever traveling, translation becomes more necessary in any kind of document. It helps tourists make informed decisions while planning out their trip: travel guides, websites, maps, menus, brochures, etc.

When it comes to the cultural field, it would be imperative to translate different forms of art such as music, film and literature, poetry, and songs of a certain region or country, so that other people can have an approach to a different culture and create a strong relationship with other countries. And enhance global tourism, because we can offer proper translation to tourists along with genuine guidance, we ensure the quality of our region as a tourist-friendly destination and ensure success.

In conclusion, knowing and learning about new cultures, economies, politics, technology, medicine, and literature is easier now, translation makes it possible. It builds bridges that defend cultural diversity and avoid ignorance, incomprehension, and fear of the unknown. Without it, it would be impossible to know the world as we know it today. Translation becomes an important tool in our modern times and facilitates every single area of our lives.

## TRANSLATION PROCESS

### Concept of translation process

Usually, when we think of translation, we believe that it is just changing the words of a text from one language to another, but in fact, we have the wrong idea of what translation is, and the process to follow when translating. More than changing words from one language to another, we need to focus on what the author of the text intends to transmit to the reader. According to Newmark (1988: 5) *“translation is a process of rendering the meaning of a text into another language in the way the author intended the text”*.

Nida and Taber define translation as *“reproducing in the receptor language the closest natural equivalent of the source language message, first in terms of meaning and secondly in terms of style”* (Nida & Taber, 1974: 12). To make our translation a success, it is necessary to follow a process. The steps to follow can vary from one translator to another, or according to the text or client’s needs, but the aim is always the same. Although the translation is made by an experienced translator or one who has no experience at all, some steps cannot be skipped, for instance: reading the text, translating the text, proofreading the translation, and a final revision. The importance of the steps before mentioned is that they help translators not only to translate words but also to keep the meaning of the text, and make it understandable for the reader of the target language, as it is mentioned by Nida and Taber *“Translators’ priority is to consider whether the translation would be read and understood by the TL readers as it is intended by the writer of the SL text”* (Nida and Taber, 1974: 8).

*“The best translation does not sound like a translation”* (Nida & Taber, 1974: 12). To fulfill the expectations of a good translation is not an easy task because it is necessary to keep the message of the text, and we also must pay special attention to aspects like style, cohesion, coherence, and accuracy. All these requirements lead to the use of different techniques that are part of the translation process like borrowing, literal translation, transposition, modulation, equivalence, and amplification, among others. These techniques make our translation sound natural, and we can also adapt the text according



to the grammatical structure of the target language without changing the meaning or the intention of the author.

To sum up, when translating a text or document, it is essential to follow a set of steps to elaborate a better version of a text in another language.

## Translation process



## Translation process steps

1

### Read the text:

Reading the text in its entirety before beginning the translation will help to get an initial idea of the topic.



2

### Analysis and research:

After reading the whole document, it is time to analyze: the type of text and the public who will read it. Moreover, to get familiar with the new vocabulary and unknown words or phrases, we continue with the research of the unknown words found in the text.



3

### Translation

Now we start translating the text little by little, adding the information gathered in the previous step and trying to give them sense.



4

### Take a break

It is recommendable to take a break to clear our mind. We can stretch, get out for a while to get some fresh air, or drink something. This pause will help us to get more energy for continuing with the following steps which are crucial for it is almost the end of the process.



5

### Compare the two versions

This step with helps the translator to verify that the text in the target language keeps the same meaning than the one from the original text.



6

### Editing and Proofreading

This step is a must, we can't skip it since we need to make sure our text in the target language is written correctly, and it sounds natural for the reader. Grammar, cohesion, and coherence are the aspects to focus on while revising the translation.



7

### Final version

The final step is essential since the translation is almost ready to be presented. For this part, we can either ask someone for help to revise the translation or we can do it by ourselves because we need to make sure our translation was well done and that it is completed.

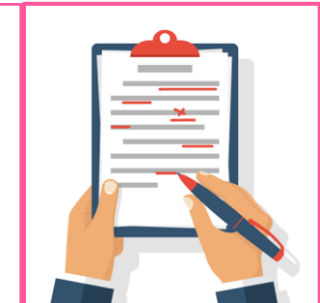

## TRANSLATIONS

### Digestive System (Original Version)

258

BIOLOGY

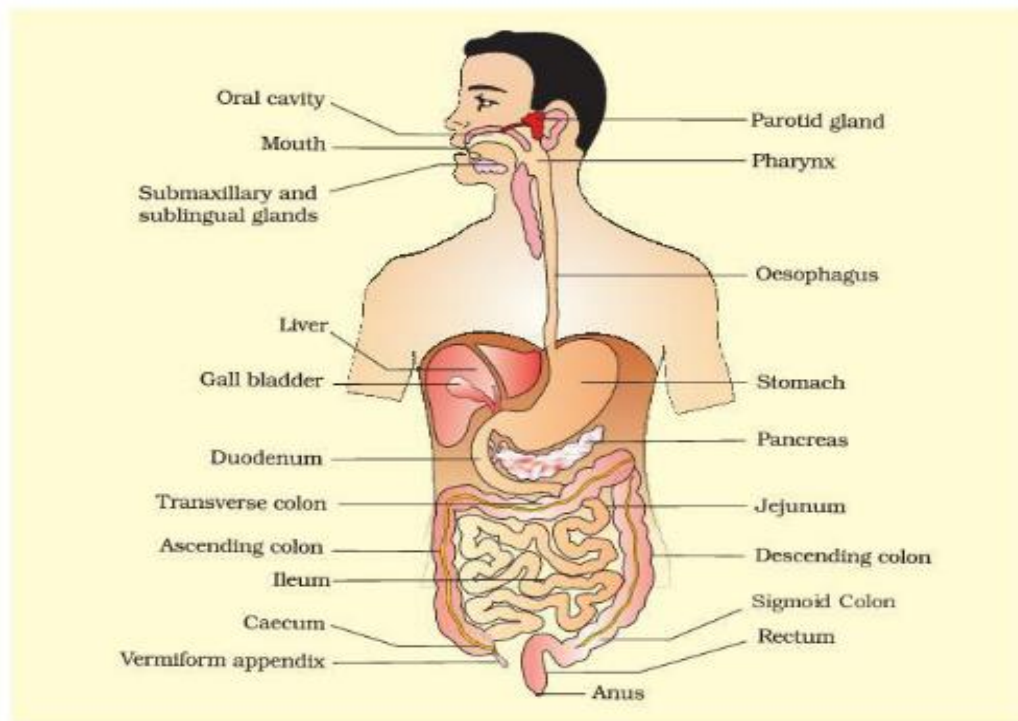

**Figure 16.1** The human digestive system

has 32 permanent teeth which are of four different types (Heterodont dentition), namely, incisors (I), canine (C), premolars (PM) and molars (M). Arrangement of teeth in each half of the upper and lower jaw in the order I, C, PM, M is represented by a dental formula which in human

is  $\frac{2123}{2123}$ . The hard chewing surface of the teeth, made up of enamel, helps in the mastication of food. The tongue is a freely movable muscular organ attached to the floor of the oral cavity by the frenulum. The upper surface of the tongue has small projections called papillae, some of which bear taste buds.

The oral cavity leads into a short pharynx which serves as a common passage for food and air. The oesophagus and the trachea (wind pipe) open into the pharynx. A cartilaginous flap called epiglottis prevents the entry of food into the glottis – opening of the wind pipe – during swallowing. The oesophagus is a thin, long tube which extends posteriorly passing through the neck, thorax and diaphragm and leads to a 'J' shaped bag



Figura 16.1 El sistema digestivo humano

tiene 32 dientes permanentes los cuales son de cuatro tipos diferentes (dentadura heterodonta), específicamente, incisivos (I), caninos (C), premolares (PM), molares (M). La disposición de los dientes en cada mitad de la mandíbula superior e inferior en el orden I, C, PM, M es representada por una fórmula que en el ser humano

es  $\frac{2123}{2123}$ . La superficie externa de los dientes está hecha de esmalte, la cual ayuda

en la masticación de la comida. La lengua es un órgano muscular de movimiento libre unido al piso de la cavidad oral por el frenillo lingual. La superficie superior de la lengua tiene pequeñas prominencias llamadas papilas, algunas de las cuales llevan papilas gustativas.

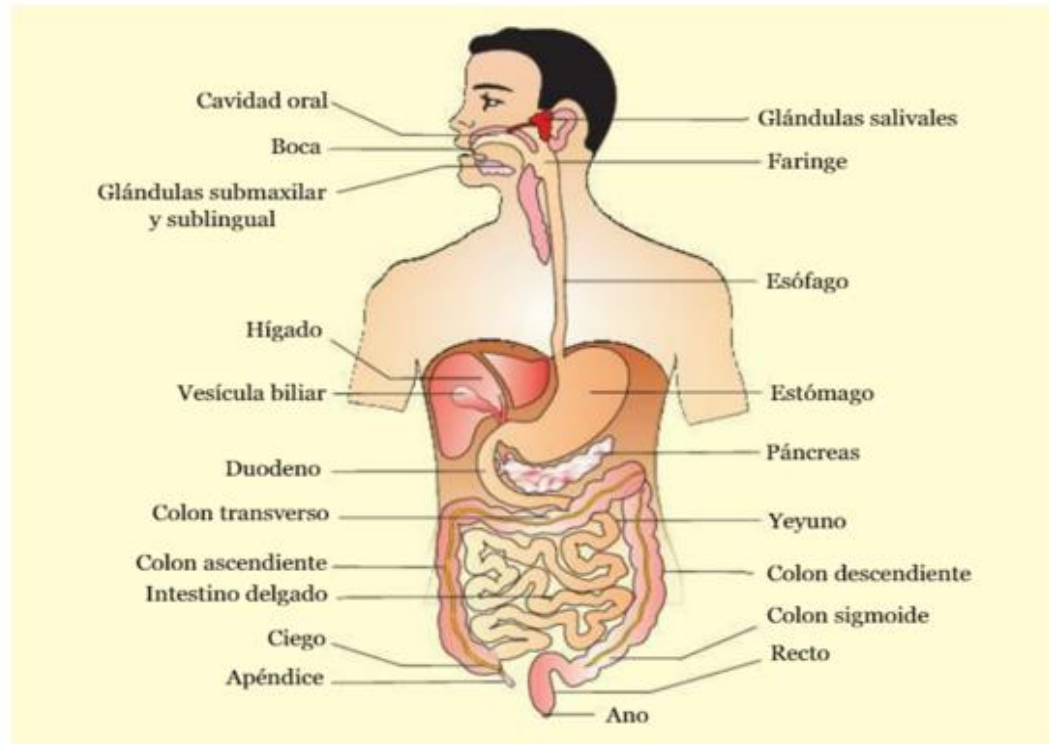
La cavidad oral desemboca en una faringe corta que sirve de paso común para los alimentos y el aire. El esófago y la tráquea se abren en la faringe. Un colgajo cartilaginoso llamado epiglotis impide la entrada de comida en la glotis (apertura de la tráquea) durante la deglución. El esófago es un tubo largo y delgado que posteriormente se extiende pasando por el cuello, el tórax, el diafragma y conduce a una bolsa en forma de "J".

**(Original Version)**

The digestive system is one of the most clearly defined in the body.

It consists of a long passageway, the digestive tract, and associated glands.

These include the liver and pancreas, which are connected to the main tract by ducts, or tubes, and empty their products, such as enzymes, into the tract.

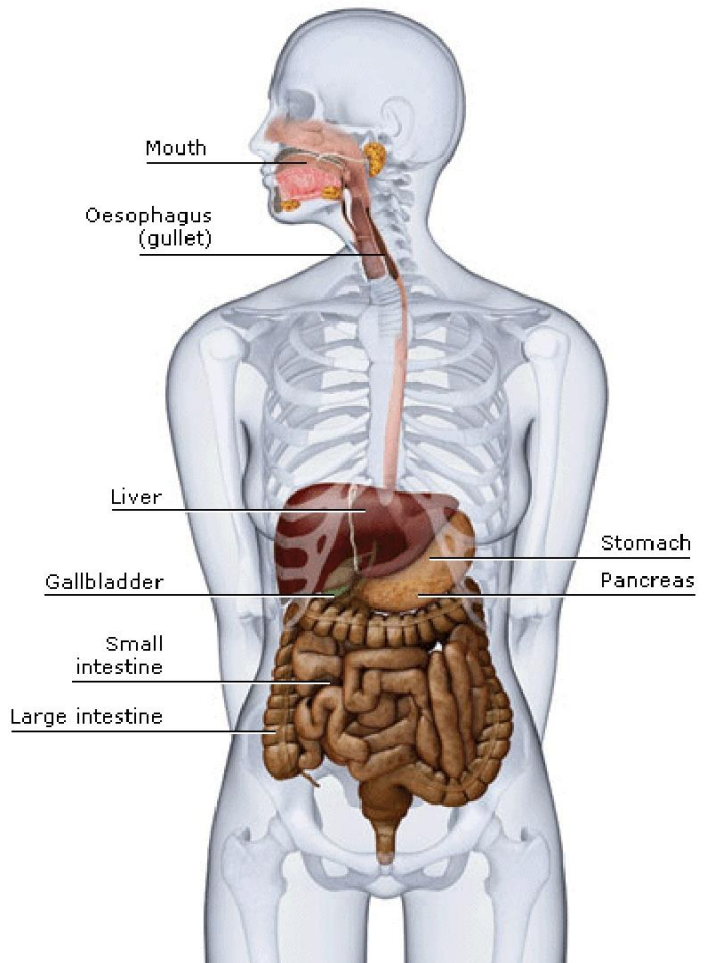



**(Translated Version)**

El aparato digestivo es uno de los más claramente definidos en el cuerpo.

Consiste en un conducto largo, el tubo digestivo y las glándulas anexas.

Entre ellas se encuentran el hígado y el páncreas, que están conectados al tracto principal por conductos o tubos, y expulsan sus productos, como las enzimas, en el tracto.

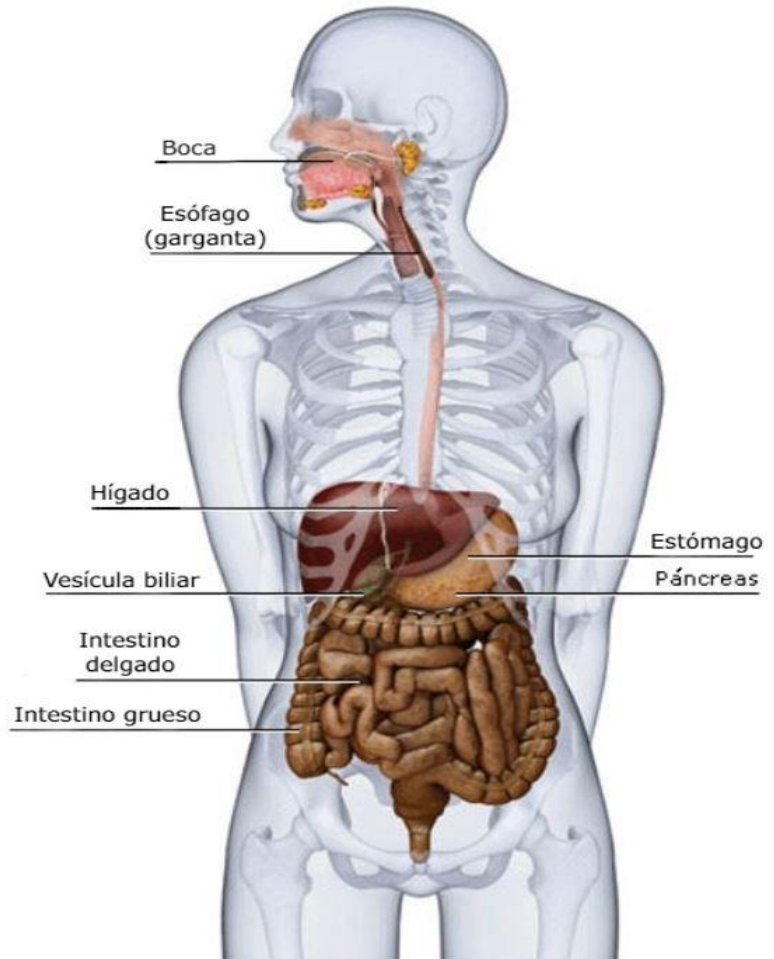



(Original Version)

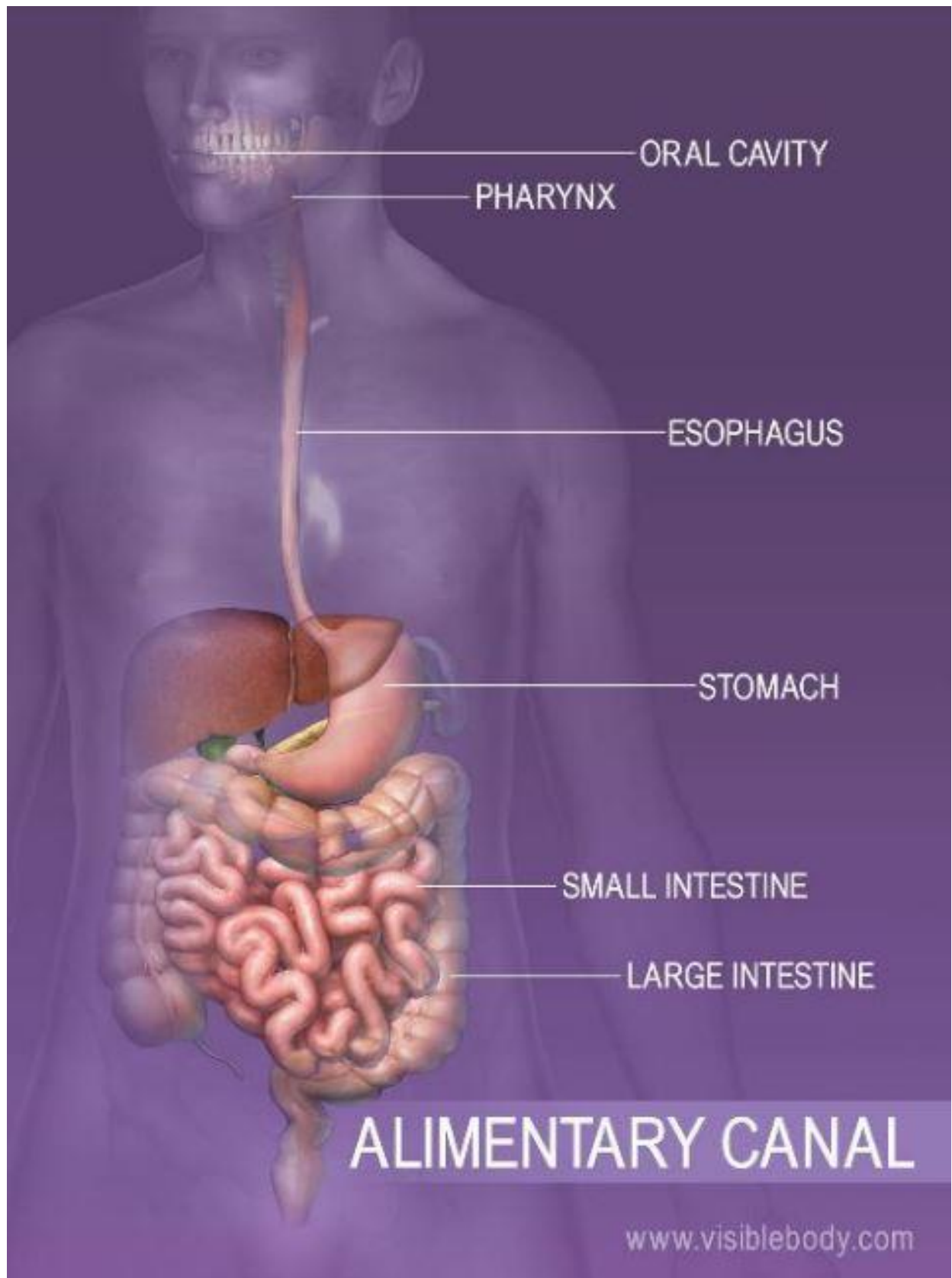

(Translated Version)



# OPERATION MANUAL

**CAR MP5 PLAYER WITH  
7 INCH HD DISPLAY PANEL  
FM RADIO RECEIVER  
BT  
MIRRORLINK**



## **Before installation**

Thank you very much for purchasing and using our products, when you receive the product, please do not take the product directly to the car for installation, because the product is in the after a long journey, it may affect the product. Please try the machine before installing.

**Test method:** Take the machine to the battery of the car and test it. This car stereo applies to a power supply voltage at 12V DC, Connect the red and yellow wires of the power cord of the machine together and connect it to the positive pole of the battery. The black wire of the power cord is connected to the negative pole of the battery. Wait for 10 seconds after connecting, press each button of the machine to see if the machine can boot normally. If it can be turned on, it means there is no problem, you can install it. If the test machine can not start normally, please again Confirm that you follow the steps of our test method in strict accordance with the operation. If the problem is still not solved, please contact our work in time.

Thank you for your cooperation.

## **BASIC PARAMETERS**

Operating Voltage	DC12V
Maximum Current	15A
Operating Temperature	-10~+60℃
Screen Size	7 Inch
Screen Resolution	800*480
System	Windows CE
Output Power	60W x 4
BT Function	Ver:4.0 Built-in microphone
Phone Link	Android/Iphone (Some high version phones do not support)
Support Video Format	RM/RMVB/FLV/3GP/MPEG/DIVX/DAT/VOB/AVI/MP4
Support Audio Format	MP3/WMA/WAV/FLAC/APE/OGG/
Support Picture Format	JPG
Button Light	Colorful light automatic / Monochrome light optional
Radio Frequency	FM 87.5~108MHz
Support media devices	USB 2.0/TF card
AUX Input	Front panel 3.5mm interface
Reverse Function	Support (camera option)
Remote Control	Infrared remote control
Language Selection	English/Chinese/Spain/Portugal/French/Italy/Russia/German/Turkey/Czech/Polish/Thai
Steering Wheel Controls	Support

## **UNIT INSTALLATION SIZE**





## PANEL COMPONENT DESCRIPTION

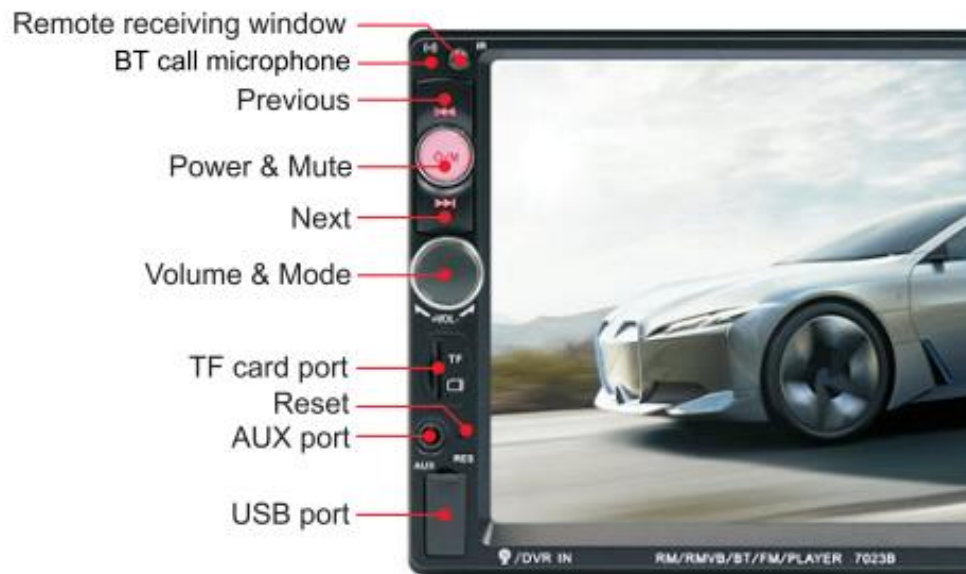

## REAR INTERFACE DESCRIPTION

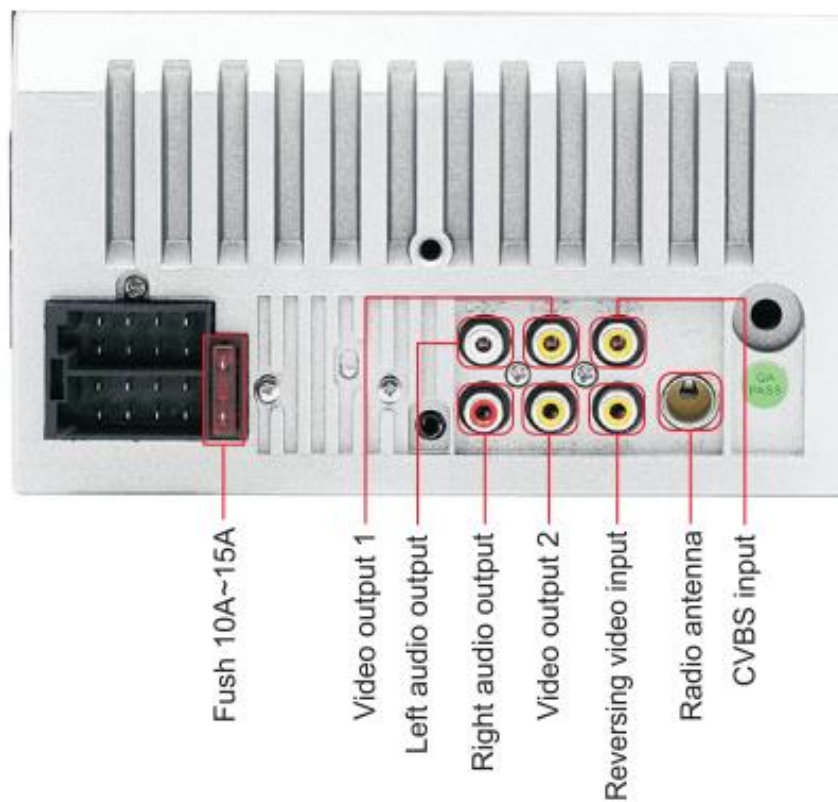

## PANEL COMPONENT DESCRIPTION

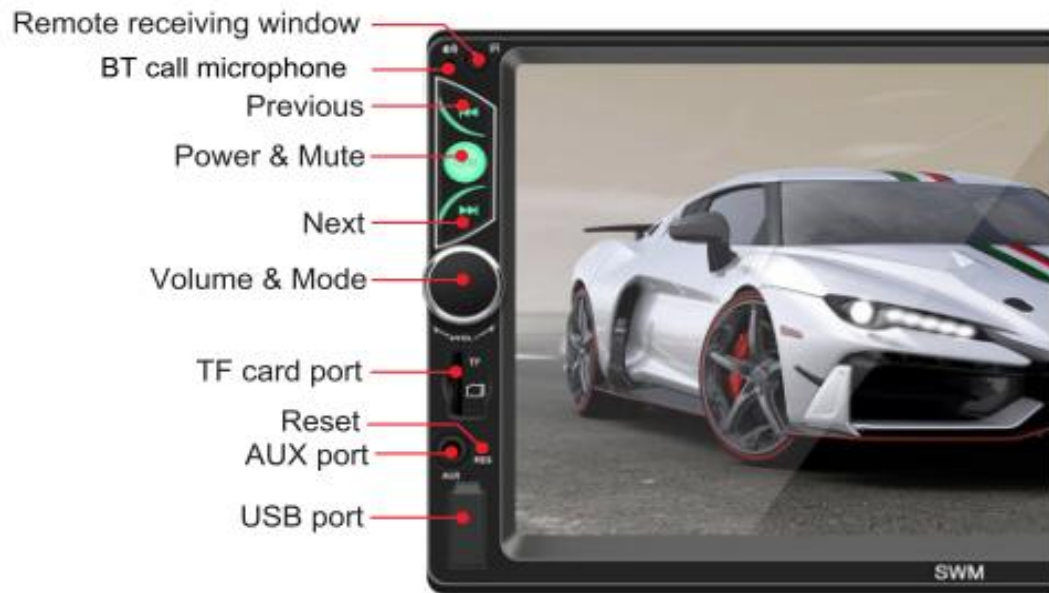

## REAR INTERFACE DESCRIPTION

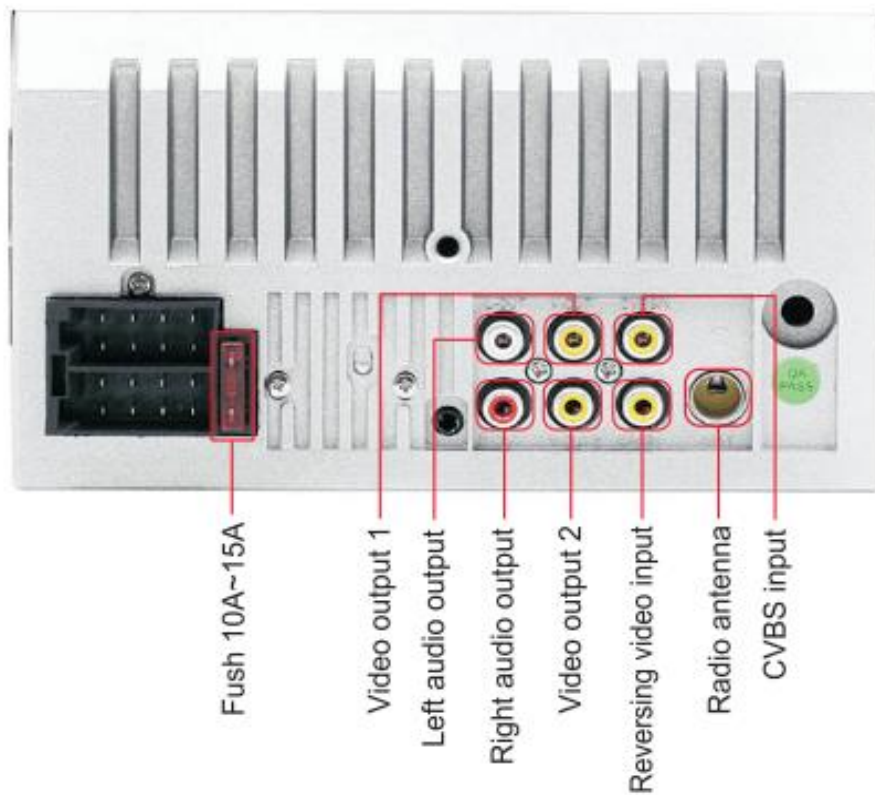

## REAR INTERFACE DESCRIPTION

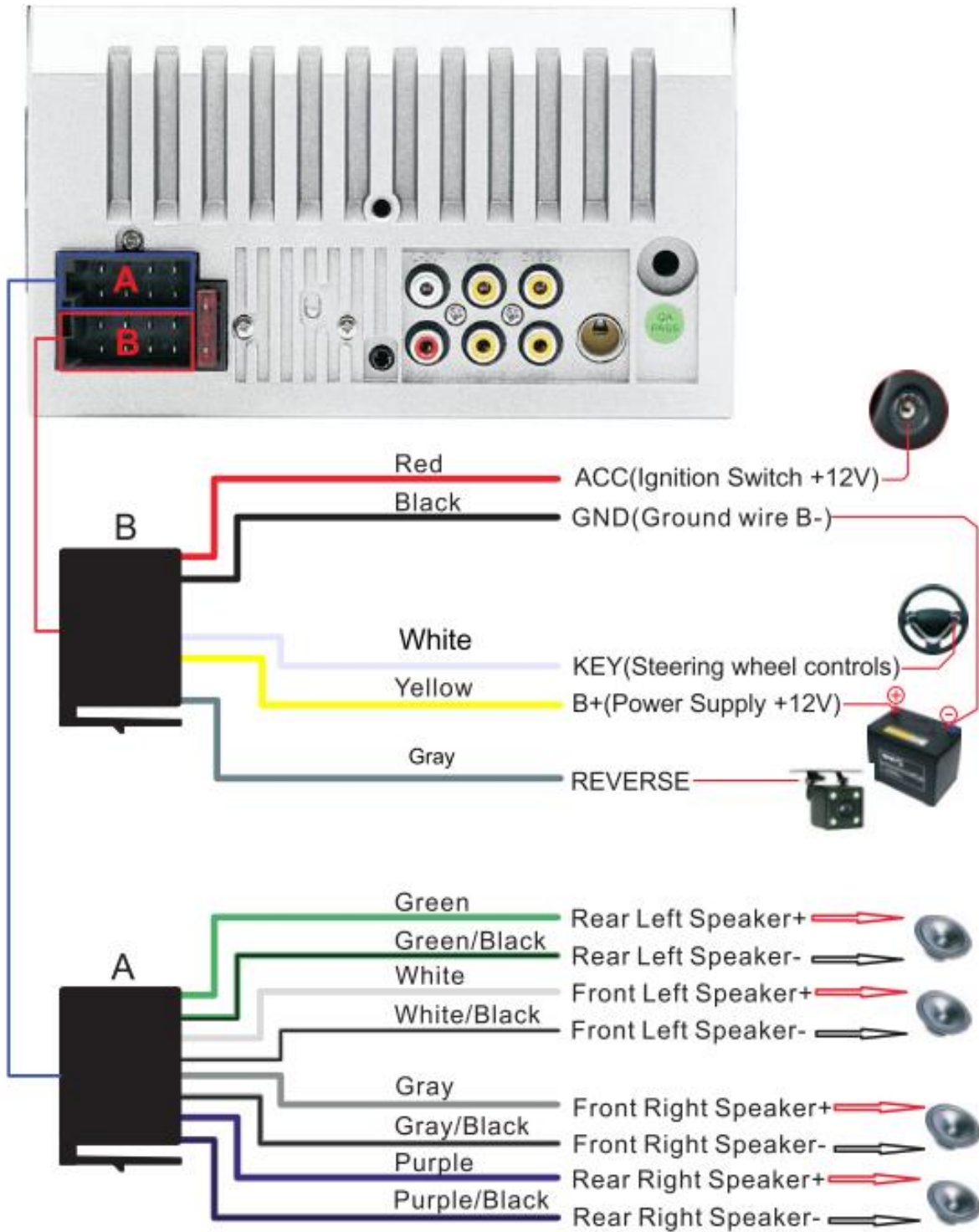



## PHONE LINK FOR IPHONE

\* For iOS, X series and higher versions of mobile phones do not support mobile "phone link" with this machine.

1. Connect the machine and mobile phone with the original data cable.
2. When the phone pops up a dialog box: Trust This Computer? Select Trust to enter the interconnect mode.



## **STEERING WHEEL CONTROLS**

1. Connect the positive pole of the original steering wheel to the KEY(White) line of the machine plug.
2. Connect the negative pole of the original car steering wheel button wire to the GND(Black) wire of the machine plug.
3. In the "settings" interface, find "Steer" and enter.
4. Enter the steer and press the button to learn. After the learning is successful, click the "OK" button on the page. After saving, you can use the buttons on the original steering wheel to control the machine.

**Learning method:** press and hold a button on the steering wheel of the original car without letting go, find the button icon corresponding to the function of the button on the steering wheel of the machine. Click this icon to change the color, indicating that the button has been successfully learned, according to the same. The way you can learn other buttons. After all the keys have been learned, click the "OK" button on the page to save the settings. If you need to relearn, please click the "RESET" button on the page and then re-learn.



## **COMMON PROBLEMS AND SIMPLE TROUBLESHOOTING**

### **1> Unable to boot normally**

--- Reason for not booting

1. "Yellow" "Red" "Black" this 3 lines only connected 2 line of them, so it will not start, it should be that the yellow line is connected to the positive pole, red line to the key control line, black to the negative pole, less connection or wrong connection does not boot.
2. The original car line and unit wiring can not be connected to the color, the color of the original car line is not standard, if you connect like that it can not only be turned on but also may burn.
3. The original car plug can't be plugged directly into the new unit, even if it just plugs in, it can't be used, otherwise it won't be turned on or burned.
4. The 3 wires are connected right, but it does not boot. Check if the fuse on the yellow line is broken. If there is no problem with the fuse, twist the yellow and red wires together. Turn on the key and press the unit's power button to see if it can be turned on.
5. Every time you change the fuse, it burns. Please don't change it again The reason is that when you first connect the positive and negative poles, the protection circuit of the unit is short-circuited. The unit can be repaired under the guidance of our master. No basis can only be returned to the after-sales or new unit. If these are no problem, or also don't boot, please make the final step to confirm, find a 12V battery or 12V power supply "yellow" and "red" twist together with the positive, black to the negative pole, press the button check if it can boot or no, if you can boot, it showed that the original car line is not right connect, or there is a problem with the car line. If it can't be boot, the unit is broken. Does not boot unit, check the line carefully, do not blindly suspect the unit problem.

### **2> Automatic shut-down**

--- Automatic shutdown usually has these following conditions

1. The cable error connect: If the blue cable (automatic antenna power supply) is connected to the power cable of the unit, an automatic shutdown will occur. Please follow the correct wiring method to solve the problem.
2. The voltage is unstable: please find a 12V-5A which one is the power supply and re-tested to see if it will automatically shut down or no. If it does not automatically shut down after the test, please replace the power supply. If it will automatically shut down, it is problem with the unit.

### **3> Having noise**

--- The general situation of noise is caused by two reasons

1. The original speaker power is too small. When the volume of the unit is turned up, there will be noise.

**Solution:** When replacing the speaker or listening to the song, the volume should not be too large.

2. The speaker cable is grounded.

**Solution:** Take the iron speaker cable. Directly connected to the speaker cable of the unit.



#### **4> Settings cannot be saved ( no memory )**

--- There is no memory function, there is only 2 points in memory

1. The yellow line and the red line are connected together (separate yellow to positive, red to key control).
2. Yellow and red are reversed (just change position).

#### **5> Car audio with BT but it can't work**

--- Check the phone to see if you can search for the unit code or no.

**Operation steps:** turn on the unit, use the phone Bluetooth search, search for CAR-MP5, then click the connection, after connecting, you can answer the phone or BT to play the song

**PIN Code:** 0000 .

#### **6> The product smoke has proved that the internal circuit has been burned and change the insurance FUSE can not solve the problem**

--- In this case, the unit needs to be repaired.

#### **7> How to adjust the sound, where is the equalizer set, the sound can not be adjusted**

--- Adjust the sound: please turn the volume to adjust.

--- Equalizer settings: In general, press the volume knob to display the equalizer SEL, and rotate the volume button to adjust each sound effect.

--- The sound cannot be adjusted: 1.Please reset the unit or unplug the power cord and plug it in. 2.The Volume knob is broken, and the knob can be replaced.

#### **8> Support no image of reversing camera**

--- Generally two situations

1. Connect the wrong line or less wiring. Camera connection method:

- a> The first step is to find accessories (accessory: one camera + one power cord + one video cable).
- b> The second step is to find the port of the wiring.First find the reversing control line on the power line of the unit. The control line is a pink line or brown line, connect this line to the positive pole of 12V and the screen will turn blue. Find the back of the unit the CAME video input interface, find the positive and negative of the backup light. The third step is to connect: there are two sockets on the camera, the red socket is connected to the power cable, the yellow is inserted into the video cable, the red wire of the power cable and the wire of the video cable are screwed together on the positive pole of the reverse lamp, and the black wire of the power cable is not used, connected, the other end of the video cable is connected to the

CAME video input interface on the back of the unit. The red line coming out of the video line is connected to the reversing control line of the power line.

2. The camera is broken. If the lamp that is properly wired to the camera is not lit, it will be broken and replaced with a new one.

### **10> USB flash disk can not be played, the card with the map can not be recognized, the card does not enter the card, the map card folder has no content?**

--- USB flash disk can not play:

Format the USB flash disk, and the file system is selected as: FAT32, re-download on or two songs and try again. If it still doesn't work, please replace the USB flash drive.

--- The map card cannot be recognized(Only for GPS models):

Insert the card into the computer to format, re-download the map or change the memory card to download the map software.

--- The card slot does not enter the card:

Check whether the memory card is inserted, the plug is broken.

--- There is no content in the map card folder(Only for GPS models):

Insert the card into the computer to view it. If there is no content, you need to download it again.

### **11> FM does not receive the program**

--- Can not receive the station check the 2 points

1. The antenna plug is not fully inserted, the antenna is disconnect or the line is disconnect.
2. Search channel, hold AMS does not let go for 2 seconds The unit will automatically search or press the up and down button to perform a channel search. Can't solve the above 2 points, Please unplug the antenna plug and find a screwdriver or a metal strip to insert it instead of the antenna.

### **12> Just installed no sound**

--- Dear customers, the unit has been tested before shipment. If there is no sound, it is usually a wiring error or the original car speaker wire is short-circuited with iron. Please do not doubt the unit. According to the steps to check it.

1. Check if the speaker cable is short-circuited and connected. Please reconnect if you have any short circuit.
2. Check how many speaker cables according to the original speaker cable if there are only 2 speaker cables to prove that the original car line does not match our unit, you need to re-route the original car line. One speaker must lead to 2 speaker wires. 2 speakers must be have 4 speaker cables to available.

### **13> After a while there is no sound**

--- Disconnect all the speaker cable from the unit (do not remove all of them), and then find an external speaker to receive the gray and purple of the tail line of the unit. Green any group, and then try to see if there is any sound. If there is a sound, it is proved that the car's speaker line is short-circuited with iron or the speaker is damaged. If there is no sound, the unit is broken.

# **MANUAL DE** **INSTRUCCIONES**

**REPRODUCTOR MP5 PARA  
AUTOMÓVIL CON  
PANEL DE PANTALLA HD  
RECEPTOR DE RADIO FM  
DE 7 PULGADAS**

**BT  
MIRRORLINK**

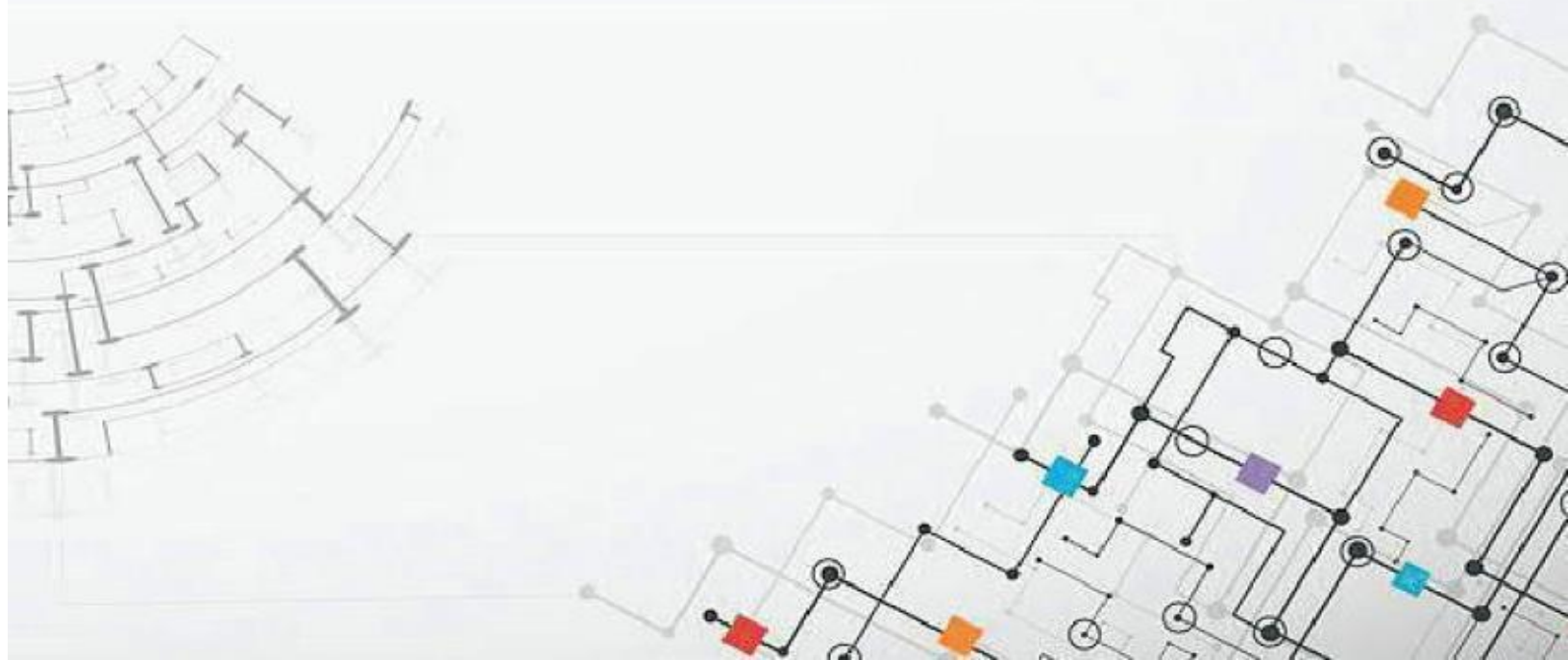

## **ANTES DE INSTALAR**

Muchas gracias por comprar y utilizar nuestros productos. Al recibir el equipo, por favor, no lo instale de inmediato en su vehículo ya que, ha sido transportado por un largo viaje y pudo verse afectado. Por favor, pruebe el equipo antes de instalarlo.

**Método de prueba:** Lleve el equipo a la batería del auto y pruébelo. Este reproductor se conecta a una fuente de alimentación de 12 Voltios en corriente directa.

Posteriormente, conecte juntos, el cable rojo y el amarillo de la fuente, al polo positivo de la batería y el cable negro al polo negativo. Espere 10 segundos después de conectarlo, presione los botones del estéreo para ver si el equipo funciona con normalidad. Si funciona, significa que no hay problema, puede instalarlo. Si no enciende con normalidad, por favor, asegúrese de haber seguido los pasos de nuestro método de prueba en estricta conformidad con la operación. Si el problema aún no se resuelve, póngase en contacto con nuestro equipo de trabajo a la brevedad posible. Gracias por su cooperación.



## **PARÁMETROS FUNDAMENTALES**

Voltaje de operación	DC12V (Corriente Directa 12 Voltios)
Corriente máxima	15A (Amperios)
Temperatura de funcionamiento	-10~+60°C
Tamaño de la pantalla	7 pulgadas
Resolución de pantalla	800x480
Sistema	Windows CE (Edición Compacta)
Potencia de salida	600W x 4 (60 Vatios x 4)
Función Bluetooth	Ver:4.0 Micrófono incorporado
Compatibilidad de teléfonos	Android/iPhone (Algunos teléfonos de gama alta no son compatibles)
Formato de video	RM/RMVB/FLV/3GP/MPEG/DIVX/DAT/VOB/AVI/MP4
Formato de audio	MP3/WMA/WAV/FLAC/APE/OGG/
Formato de imagen	JPG
Luz del botón	Luz colorida automática / Luz monocromática opcional
Radiofrecuencia	FM 87.5~108MHz
Compatibilidad de dispositivos multimedia	USB 2.0/ Tarjeta TF (Tarjeta TransFlash)
Entrada auxiliar	Interface de panel frontal de 0.35 cm
Función inversa	Compatibilidad (opción de cámara)
Control remoto	Control remoto por infrarrojos
Selección de idioma	Inglés/chino/español/portugués/francés/italiano/ruso/alemán/turco/checo/polaco/tailandés
Controles en el volante	Soporte

## **TAMAÑO DE LA INSTALACIÓN**





## DESCRIPCIÓN DEL PANEL DE CONTROL

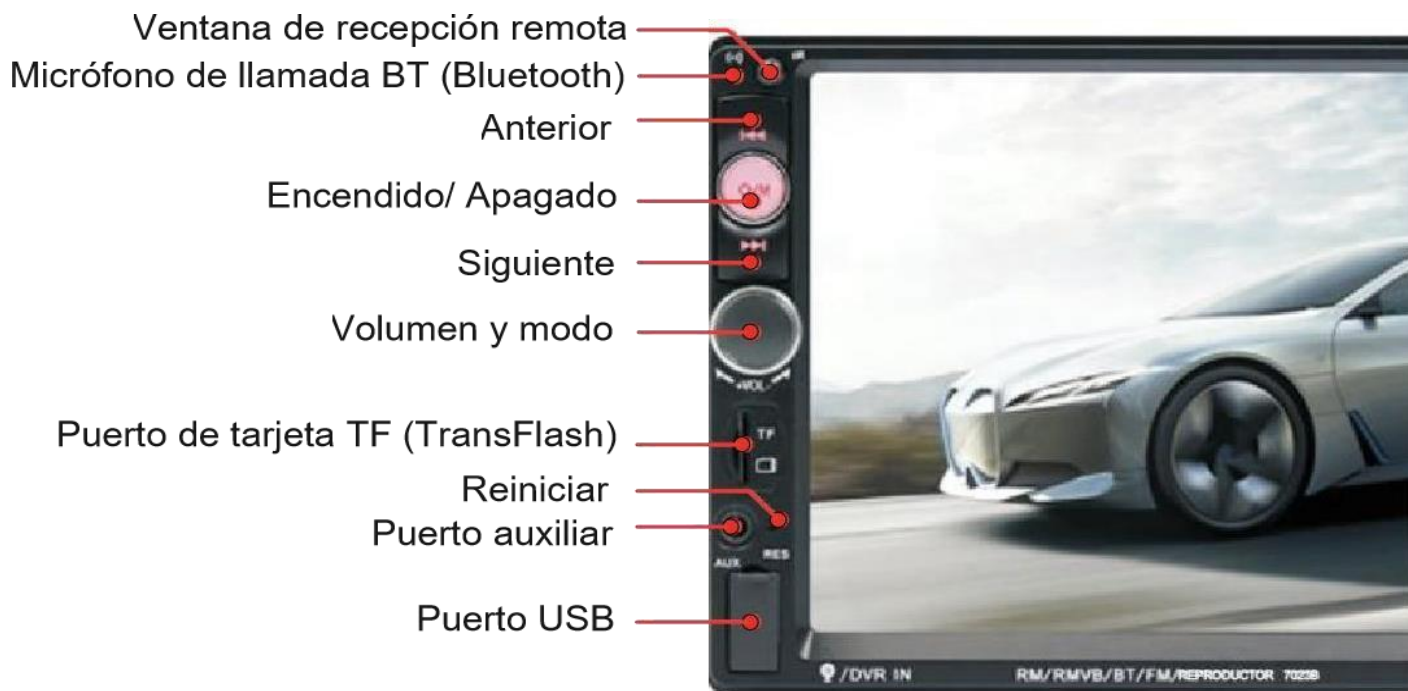

## DESCRIPCIÓN DE LAS CONEXIONES DE LA PARTE POSTERIOR

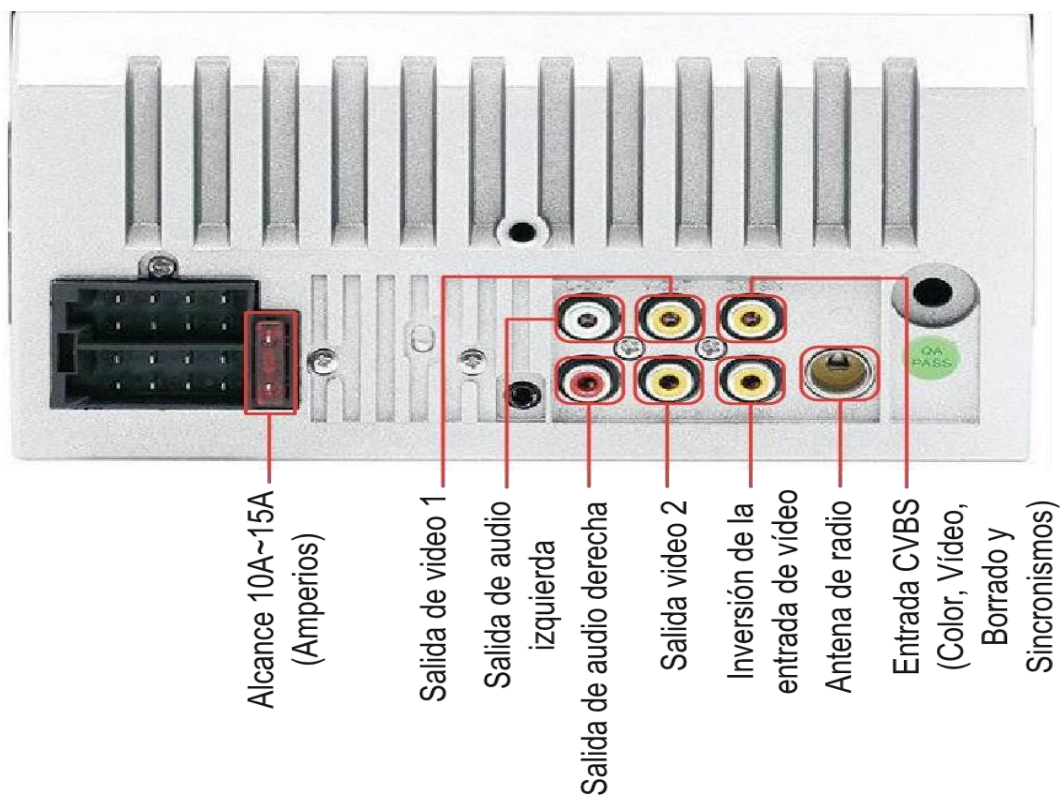

## DESCRIPCIÓN DEL PANEL DE CONTROL

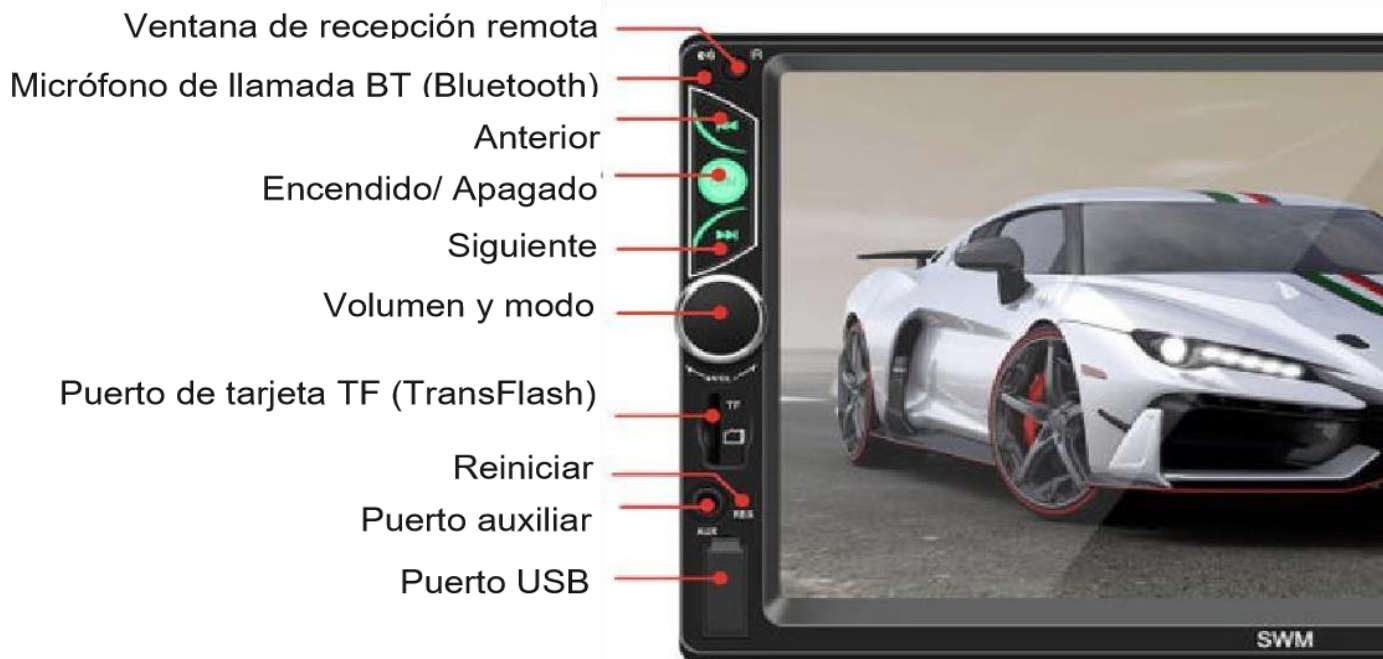

## DESCRIPCIÓN DE LAS CONEXIONES DE LA PARTE POSTERIOR

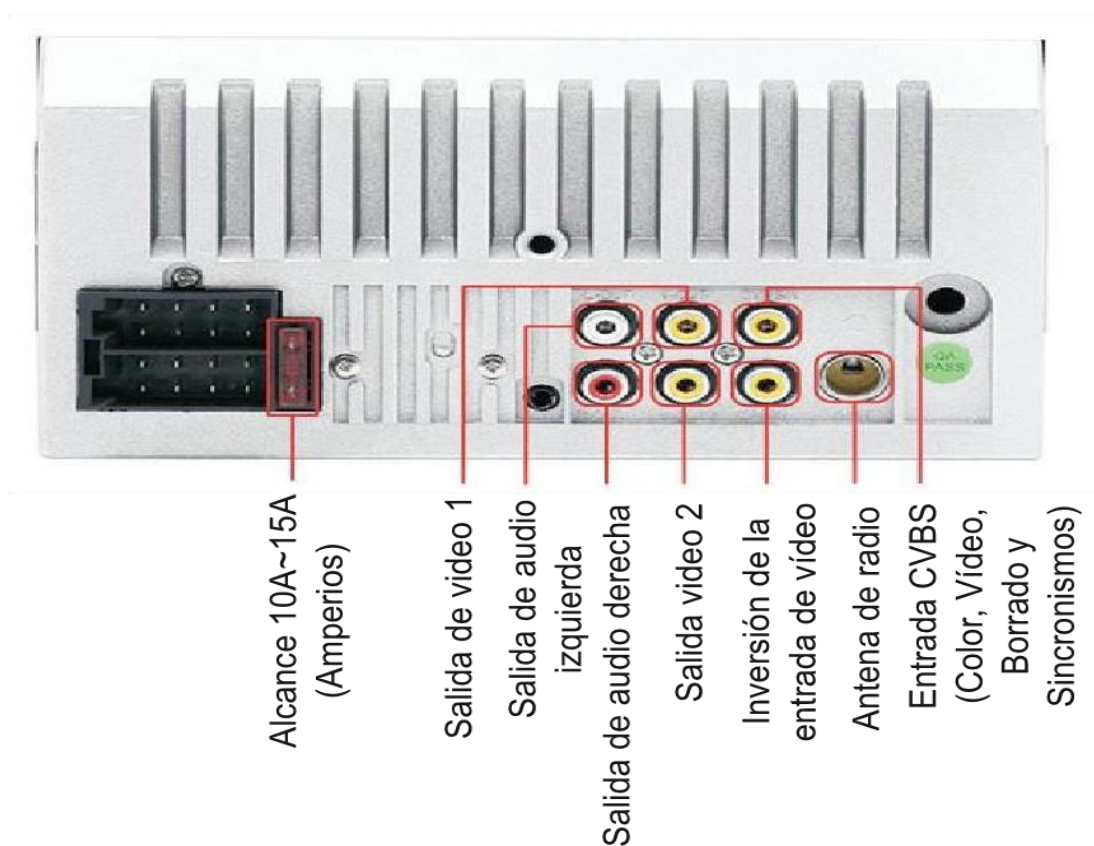

## DESCRIPCIÓN DE LAS CONEXIONES DE LA PARTE POSTERIOR

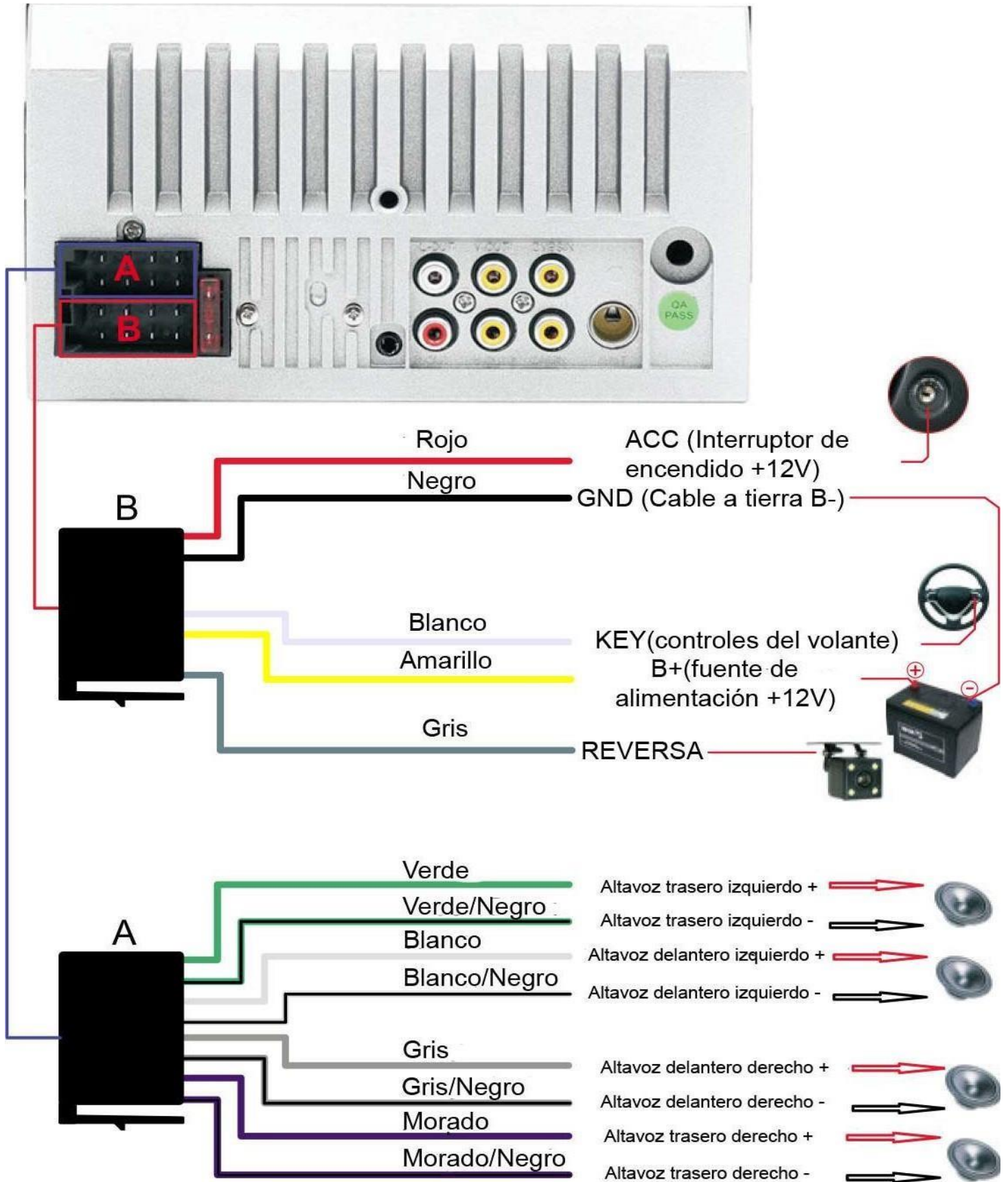



## COMO ENLAZAR CON IPHONE

\* Para iOS, la serie X y versiones superiores de teléfonos móviles no admiten el "enlazar con teléfono" con este reproductor.

1. Conecte el reproductor y el teléfono móvil con el cable de datos original.
2. Cuando el teléfono aparece un cuadro de diálogo: ¿Confiar en este ordenador? Seleccione Confiar para enlazar el teléfono.

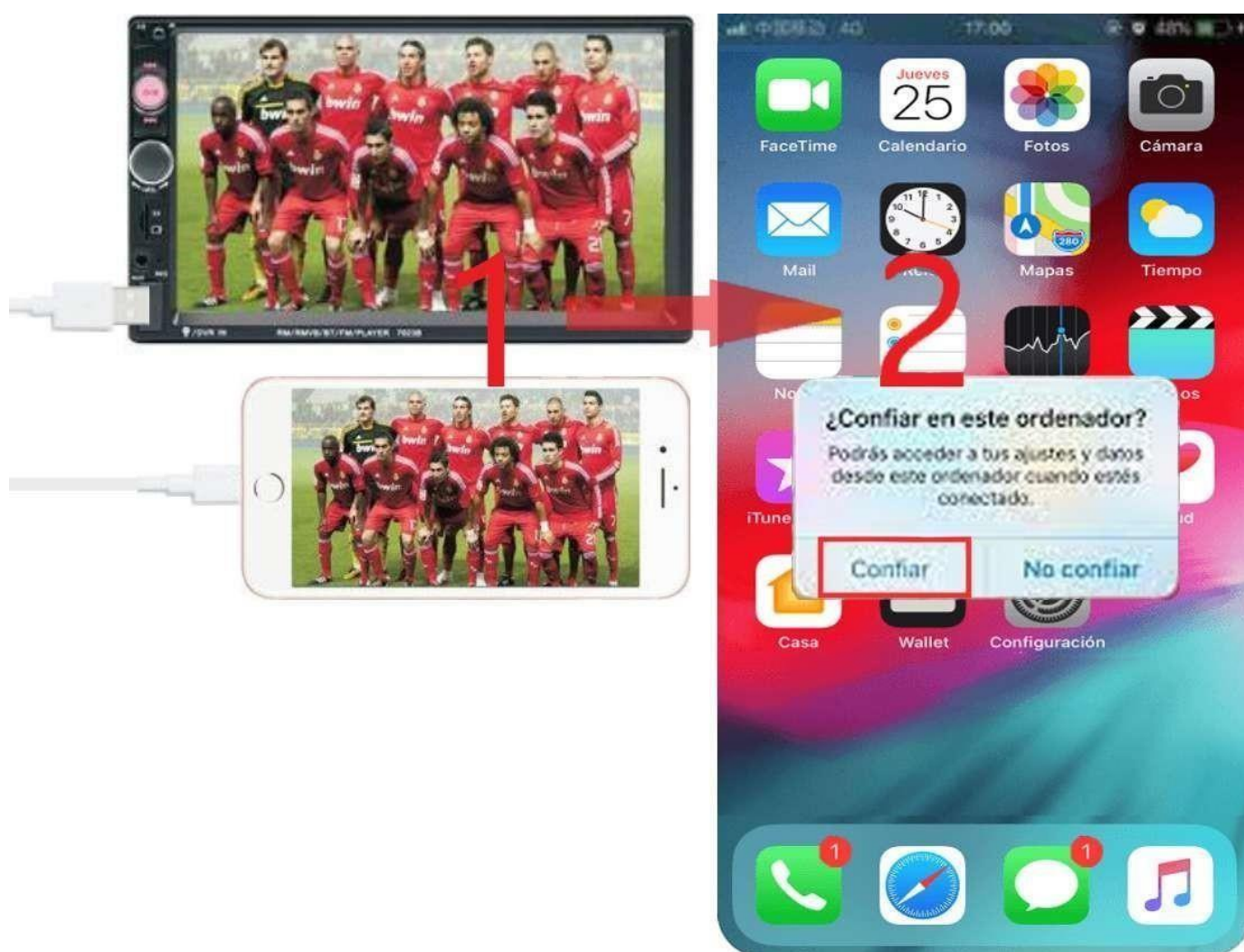

## **CONTROLES DEL VOLANTE**

1. Conecte el polo positivo del volante original al cable blanco (controles del volante) del enchufe de la máquina.
2. Conecte el polo negativo del cable del botón del volante del vehículo original al cable negro GND (cable a tierra) del enchufe de la máquina.
3. En la interfaz de "configuración", busque "Dirección" e ingrese.
4. Luego presione el botón para prender.  
Después de que haya fijado el botón con éxito, haga clic en el botón "Aceptar" en la página.  
Después de guardar, puede utilizar los botones del volante original para controlar la máquina.

**Modalidad de aprendizaje:** mantenga presionado un botón en el volante del vehículo original sin soltarlo, busque el ícono del botón correspondiente a la función del botón en el volante del vehículo. Haga clic en este icono para cambiar el color, lo que indica que el botón se ha activado con éxito, de la misma manera puede encender otros botones. Una vez aprendidos todos los botones, haga clic en el botón "Aceptar" en la página para guardar la configuración. Si necesita volver a fijar los botones, haga clic en el botón "RESTABLECER" en la página y luego vuelva a fijarlos.



## **PROBLEMAS COMUNES Y SOLUCIONES SENCILLAS**

### **1> No enciende con normalidad**

--- Razón por la que no enciende

1. "Amarillo" "Rojo" "Negro" de estas tres líneas solo están conectadas dos de ellas, esto no permitirá un correcto funcionamiento, el cable amarillo debe estar conectado al polo positivo, el cable rojo a la línea de control de la llave, y el cable negro al polo negativo. Si no todos están conectados o se conectan de forma errónea, no encenderá.
2. Evite conectar la línea de coche original y el cableado de la unidad debido a que el color de la línea de coche original no es estándar, si se conectaran así, no solo se encenderá, sino que también puede arruinarse.
3. El enchufe original del coche no se puede conectar de manera directa en la nueva unidad, incluso si encaja a la perfección, no se puede utilizar, de lo contrario no encenderá o se quemará.
4. Los 3 cables están conectados en el orden correcto, pero no enciende. Compruebe si el fusible de la línea amarilla está dañado. Si no hay ningún problema con el fusible, intercambie los cables amarillo y rojo. Introduzca la llave y pulse el botón de encendido de la unidad para comprobar si enciende.
5. Cada vez que cambias el fusible, se quema. Por favor, no lo vuelva a cambiar ya que al conectar por primera vez los polos positivo y negativo, el circuito de protección de la unidad se cortocircuita. La unidad puede repararse bajo la supervisión del experto. No se puede devolver ninguna base sólo al departamento de posventa o la unidad nueva. Si este no es el problema, pero aún no funciona, realice el último paso para confirmar. Busque una batería de 12V o una fuente de alimentación de 12V, enrosque el cable " amarillo " y " rojo " en el polo positivo, y el negro en el polo negativo. Luego, presione el botón para verificar si funciona o no. Si está funcionando, quiere decir que la línea original del vehículo no está bien conectada, o que hay un problema con la línea del vehículo. Si no es posible arrancar, la unidad está rota. Si la unidad no funciona, revise la línea con cuidado, no suponga el problema de la unidad.

### **2> Apagado automático**

--- El apagado automático suele tener estas condiciones

1. Error de conexión del cable: Si el cable azul (fuente de alimentación automática de la antena) está conectado al cable de alimentación de la unidad, se apagará de forma automática. En este caso, siga el método de cableado correcto para resolver el problema.
2. Voltaje inestable: por favor, busque una fuente de poder de 12V-5A y compruebe si se apaga o no de forma automática. Si no se apaga de manera automática después probarla, reemplace la fuente de poder. Si se apaga por sí misma, es un problema de la unidad.

### **3> Problemas de ruido**

--- El ruido en general es causado por dos razones

1. La potencia del altavoz original es demasiado baja. Por lo que, al subir el volumen, se producen ruidos.  
**Solución:** Al cambiar el altavoz o escuchar la canción, el volumen no debe ser demasiado alto.
2. El cable del altavoz está conectado a tierra.  
**Solución:** Utilice el cable del altavoz de hierro. Y conéctelo al cable de los altavoces de la unida

#### **4> Los ajustes no pueden ser guardados (sin memoria)**

--- No hay función de memoria, solo pueden ocurrir dos escenarios:

1. La línea amarilla y la línea roja están conectadas juntas (separe amarillo a positivo, rojo a clave de control).
2. Las líneas amarillo y rojo están invertidas (sólo cambiar de posición).

#### **5> No funciona el audio conectado a Bluetooth**

--- Revise el teléfono para ver si es posible encontrar el código del dispositivo o no.

**Pasos:** encienda el teléfono, usar la búsqueda para encontrar la opción Bluetooth y conectar con CARMP5. Luego hacer clic en la opción "Conexión". Después de conectarse, puede contestar el teléfono o usar Bluetooth para reproducir alguna canción.

**Código de PIN:** 0000.

**6> El dispositivo está humeando y se ha demostrado que el circuito interno se ha quemado. Cambiar el FUSIBLE del seguro no puede resolver el problema** --- En este caso, la unidad necesita ser reparada.

**7> Cómo ajustar el sonido, dónde encontrar el ecualizador, el sonido no se puede ajustar.**

--- Ajuste el sonido: girar el botón del volumen para ajustarlo.

--- Configuración del ecualizador: Generalmente, se presiona el botón del volumen para desplegar el menú del ecualizador y se gire el botón de volumen para ajustar cada efecto de sonido.

--- El sonido no se puede ajustar: 1. Por favor, restablezca la unidad o desenchufe el cable de alimentación y conéctelo. 2. El botón del volumen está roto y éste se puede reemplazar.

**8> No es compatible con la imagen de la cámara de visión trasera**

--- Generalmente se dan los siguientes escenarios:

1. Conexión de la línea equivocada o menos cableado. Método de conexión de la cámara:
  - a > El primer paso es encontrar los accesorios que se ocuparan (accesorio: una cámara + un cable de alimentación + un cable de vídeo).
  - b > El segundo paso es encontrar el puerto del cableado. Primero, encuentre la línea de control de inversión en la línea de alimentación de la unidad. La línea de control es una línea rosa o marrón, conecte esta línea al polo positivo de 12V y la pantalla se volverá azul. Encuentre la parte posterior de la unidad de la interfaz de entrada de vídeo CAME, encontrar el positivo y negativo de la luz de retroceso. El tercer paso es conectar: hay dos enchufes en la cámara, el enchufe rojo se conecta al cable de alimentación, el amarillo se inserta en el cable de vídeo, el cable rojo del cable de alimentación y el cable del cable de vídeo se atornillan juntos en el polo positivo del amplificador inverso y el cable negro del cable de alimentación no se utiliza conectado, el otro extremo del cable de vídeo se conecta a la interfaz de entrada de vídeo CAME en la parte posterior de la unidad. La línea roja que sale de la línea de vídeo está conectada a la línea de control de inversión de la línea eléctrica.



2. La cámara está rota. Si la lámpara que está correctamente conectada a la cámara no está encendida, debe estar rota y se debe reemplazar por una nueva.

## **10> ¿No se detecta la memoria USB? ¿La tarjeta no encaja en el puerto? ¿El dispositivo no reconoce el sistema de navegación de su tarjeta o la carpeta está vacía?**

--- La unidad de memoria USB no puede ser leída:

Formatee la memoria USB, y seleccione FAT32 como sistema de archivo, vuelva a descargar una o dos canciones e inténtelo de nuevo. Si el problema persiste, reemplace la unidad de memoria USB.

--- No es posible reconocer la tarjeta SD de Mapa (solo para modelos GPS):

Inserte la tarjeta SD en el ordenador para formatear, y vuelva a descargar sistema de navegación; o reemplace la tarjeta SD y descárguelo en la nueva tarjeta de memoria.

--- La tarjeta de memoria no encaja en la ranura SD:

Compruebe si la tarjeta de memoria está insertada de manera correcta, o si los conectores están dañados.

--- La carpeta de navegación de la tarjeta SD está vacía (solo para modelos GPS): Inserte la tarjeta en el ordenador para verificar. Si no se muestra ningún contenido, descargue de nuevo el sistema de navegación en la tarjeta.

## **11> No hay señal con la frecuencia FM**

--- No se puede sintonizar las estaciones, compruebe lo siguiente:

1. El enchufe de la antena no está correctamente insertado, la antena está desconectada o la línea está desconectada.
2. Seleccione un canal para sintonizar, mantenga pulsado el botón AMS por 2 segundos. El reproductor buscará de forma automática, o pulse el botón arriba y abajo para realizar una búsqueda de canal. Si no puede resolver los 2 puntos anteriores, desconecte el enchufe de la antena y busque un destornillador o una tira de metal para insertarlo en lugar de la antena.

## **12> Recién instalado sin sonido.**

--- Estimados clientes, la unidad ha sido probada antes del envío. Si el sonido no funciona, es posible que exista un error de cableado o el cable original del altavoz del automóvil tiene cortocircuito. Por favor, no desconfíe de la unidad. Siga los pasos para comprobarlo.

1. Compruebe que el cable del altavoz está haciendo cortocircuito y conectado. Por favor, vuelva a conectar el cable si tiene algún corto circuito.
2. Compruebe cuántos cables hay en función para conectar el cable de altavoz original. Si sólo hay 2 cables de altavoz para demostrar que la línea del automóvil original no coincide con nuestra unidad, es necesario volver a redirigir la línea original del automóvil. Un altavoz debe conducir a 2 cables de altavoz. 2 altavoces deben tener 4 cables de altavoz disponibles.

## **13> Después de un tiempo no hay sonido**

--- Desconecte todos los cables del altavoz de la unidad (no los quite todos), y luego busque un altavoz externo para recibir el cable gris y el púrpura de la línea trasera de la unidad. Debe unir cualquier grupo de cables, y luego trate de ver si hay algún sonido. Si hay un sonido, se demuestra que la línea del altavoz del carro tiene cortocircuito o el altavoz está dañado. Si no hay sonido, la unidad está quebrada.



Birth Certificate

Folio 10 Libro 90. "A"



PARTIDA NUMERO O C H O . . . . .

NAYIB ARMANDO, sexo masculino . . . . . nació a las dos horas, quin-  
 ce minutos . . . . . del día veinticuatro de Julio del  
 pasado/ año próximo/ en. el hospital Centro Ginecológico; . . . . .  
 es hijo de ARMANDO - BUKELE KATTAN . . . . . y de OLGA MARINA-  
 ORTEZ . . . . . el primero de treinta y siete . . . . .  
 años de edad, doctor en química <sup>trial</sup> / originario de esta ciudad . . . . .  
 . . . . . del domicilio de la misma . . . . .  
 . . . . . y de nacionalidad salvadoreña . . . . . y la segunda, de veinti-  
 cuatro . . . . . años de edad, estudiante . . . . . originaria de  
 Concepción de Oriente, La Unión . . . . . del domicilio de esta ciudad . . . . .  
 . . . . . y de nacionalidad salvadoreña . . . . . Dio estos  
 datos ARMANDO - BUKELE KATTAN . . . . . quien manifiesta ser  
 padre del inscrito . . . . . Exhibió su Cédula de Identidad . . . . .  
 Personal número uno- uno- ciento noventa y siete mil, quinientos  
 ochenta y ocho, expedida en esta ciudad . . . . .  
 y . . . firma . . . . .

ALCALDIA MUNICIPAL, San Salvador, catorce . . . . . de Julio . . . . .  
 de mil novecientos ochenta y dos. Entre líneas-pasado-trial-Vale. . . . .

*[Handwritten signature]*  
 Informante

*[Handwritten signature]*  
 Jefe del Registro Civil

NAYIB ARMANDO BUKELE ORTEZ, contrajo matrimonio civil con GABRIELA ROBERTA RODRIGUEZ PEREZALONSO, el día seis de diciembre de dos mil catorce, ante CONAN TONATHIU CASTRO, NOTARIO, en SAN SALVADOR, los contrayentes optan por el Régimen Patrimonial SEPARACION DE BIENES, la contrayente usará los apellidos RODRIGUEZ DE BUKELE. Alcaldía Municipal: San Salvador, veintidós de diciembre de dos mil catorce.

*[Handwritten signature]*  
 LIC. JUAN JOSÉ ARMANDO AZUCENA CATÁN  
 JEFE DEL REGISTRO DEL ESTADO FAMILIAR





BIRTH CERTIFICATE NUMBER EIGHT - - - - - was born at two hours, fifteen minutes - - - - - on July twenty-four of the last/coming year, at the Gynecological Center Hospital; - - son of ARMANDO - BUKELE KATTAN - - - - - and OLGA MARINA-ORTEZ - - - - - the first is thirty-seven - - - - - years old, Doctor in Industrial Chemistry, originally from this city - - - - -, domicile of this city - - - - - Salvadoran nationality - - - -, and the second is twenty-four - - - - - years old, student - - - - -, originally from Concepción de Oriente, La Unión -, domicile of this city -- - - - - Salvadoran nationality - - - - -. This information was provided by ARMANDO - BUKELE KATTAN - - - - -who states to be the father of the newborn - - - - -. He exhibited his Personal Identity Card number one - one - one hundred ninety-seven - - - thousand, five hundred eighty- eight, issued in this city - - - and signed, - - - - - San Salvador, City Hall, July - - - - fourteenth - - - - - one thousand nine hundred eighty-two. Between lines-past-trial-Vale.

*Signature*

Director of the civil register

*Signature*

Deponent

NAYIB ARMANDO BUKELE ORTEZ, got married by civil law to GABRIELA ROBERTA RODRIGUEZ PEREZ ALONSO, on December sixth, two thousand fourteen, in presence of CONAN TONATHIU CASTRO, NOTARY, in San Salvador, the spouses agreed on the DIFFERED COMMUNITY STATE, the wife will get the last names RODRIGUEZ DE BUKELE. City Hall: San Salvador, December twenty-second, two thousand fourteen.

*Signature*

LIC. JUAN JOSE ARMANDO AZUCENA CATÁN  
DIRECTOR OF THE FAMILY STATUS REGISTRY



UNIVERSIDAD DE EL SALVADOR

1998



1998

Nº 532021

CINCUENTA CENTAVOS

1 LA INFRASCrita SECRETARIO DE ASUNTOS ACADEMICOS AD-HONOREM, DE LA UNIVERSIDAD  
 2 DE EL SALVADOR, CERTIFICA QUE: [REDACTED] CURSO Y APROBO  
 3 EN ESTA UNIVERSIDAD DESDE EL AÑO ACADEMICO 1986-1987, AL AÑO ACADEMICO 1990-1991  
 4 LAS ASIGNATURAS ABAJO DETALLADAS SIENDO ACTUALMENTE GRADUADA EN LA CARRERA DE  
 5 LICENCIATURA EN QUIMICA Y FARMACIA.-

AÑO ACADEMICO 1986-1987 CICLO I			
7	INGLES I	8.9	OCHO PUNTO NUEVE APROBADA
8	QUIMICA GENERAL I	8.8	OCHO PUNTO OCHO APROBADA
9	FISICA I	9.1	NUEVE PUNTO UNO APROBADA
10	MATEMATICA I	9.4	NUEVE PUNTO CUATRO APROBADA
AÑO ACADEMICO 1986-1987 CICLO II			
12	QUIMICA GENERAL II	8.8	OCHO PUNTO OCHO APROBADA
13	MATEMATICA II	9.7	NUEVE PUNTO SIETE APROBADA
14	FISICA II	9.6	NUEVE PUNTO SEIS APROBADA
15	INGLES II	8.0	OCHO PUNTO CERO APROBADA
16	TECNICAS DE REDACCION E INVESTIGACION	9.2	NUEVE PUNTO DOS APROBADA
AÑO ACADEMICO 1987-1988 CICLO I			
18	MATEMATICA III	9.2	NUEVE PUNTO DOS APROBADA
19	QUIMICA INORGANICA I	7.8	SIETE PUNTO OCHO APROBADA
20	QUIMICA ORGANICA I	8.5	OCHO PUNTO CINCO APROBADA
21	QUIMICA ANALITICA I	8.1	OCHO PUNTO UNO APROBADA
AÑO ACADEMICO 1987-1988 CICLO II			
23	QUIMICA ORGANICA II	6.5	SEIS PUNTO CINCO APROBADA
24	QUIMICA ANALITICA II	7.6	SIETE PUNTO SEIS APROBADA

1	BIOLOGIA GENERAL	8.3	OCHO PUNTO TRES	APROBADA
2	ESTADISTICA	7.7	SIETE PUNTO SIETE	APROBADA
3	SOCIOLOGIA GENERAL	8.7	OCHO PUNTO SIETE	APROBADA
4	AÑO ACADÉMICO 1988-1989 CICLO I			
5	QUIMICA ORGANICA III	7.5	SIETE PUNTO CINCO	APROBADA
6	PSICOLOGIA APLICADA A LA EMPRESA	9.3	NUEVE PUNTO TRES	APROBADA
7	QUIMICA FISICA I	6.7	SEIS PUNTO SIETE	APROBADA
8	BIOQUIMICA GENERAL	7.8	SIETE PUNTO OCHO	APROBADA
9	ZOOLOGIA GENERAL Y FARMACEUTICA	8.0	OCHO PUNTO CERO	APROBADA
10	AÑO ACADÉMICO 1988-1989 CICLO II			
11	QUIMICA FISICA II	7.9	SIETE PUNTO NUEVE	APROBADA
12	ANATOMIA	8.6	OCHO PUNTO SEIS	APROBADA
13	MICROBIOLOGIA Y PARASITOLOGIA	8.5	OCHO PUNTO CINCO	APROBADA
14	BOTANICA GENERAL Y FARMACEUTICA	8.5	OCHO PUNTO CINCO	APROBADA
15	PRINCIPIOS DE ADMINISTRACION	7.6	SIETE PUNTO SEIS	APROBADA
16	AÑO ACADÉMICO 1989-1990 CICLO I			
17	FARMACOQUIMICA	7.8	SIETE PUNTO OCHO	APROBADA
18	FISIOLOGIA	8.4	OCHO PUNTO CUATRO	APROBADA
19	FARMACOGNOSIA	8.0	OCHO PUNTO CERO	APROBADA
20	QUIMICA ANALITICA III	8.7	OCHO PUNTO SIETE	APROBADA
21	QUIMICA AGRICOLA APLICADA I	8.6	OCHO PUNTO SEIS	APROBADA
22	AÑO ACADÉMICO 1989-1990 CICLO II			
23	ANALISIS BROMATOLOGICO	8.3	OCHO PUNTO TRES	APROBADA
24	FARMACOTECNIA	8.7	OCHO PUNTO SIETE	APROBADA

PASA A LA HOJA No. 192121





CINCUENTA CENTAVOS

1	FARMACOLOGIA	9.0	NUEVE PUNTO CERO	APROBADA
2	QUIMICA AGRICOLA APLICADA II	9.6	NUEVE PUNTO SEIS	APROBADA
3	AÑO ACADÉMICO 1990-1991 CICLO I			
4	CONTROL DE CALIDAD DE PRODUCTOS FARMA-			
5	CEUTICOS HUMANOS Y VETERINARIOS I	8.1	OCHO PUNTO UNO	APROBADA
6	TECNOLOGIA FARMACEUTICA I	8.6	OCHO PUNTO SEIS	APROBADA
7	QUIMICA LEGAL Y ANALISIS TOXICOLOGICO	8.3	OCHO PUNTO TRES	APROBADA
8	CONTAMINACION AMBIENTAL Y SALUD PUBLICA	7.7	SIETE PUNTO SIETE	APROBADA
9	QUIMICA AGRICOLA APLICADA III	9.1	NUEVE PUNTO UNO	APROBADA
10	AÑO ACADÉMICO 1990-1991 CICLO II			
11	CONTROL DE CALIDAD DE PRODUCTOS FARMA-			
12	CEUTICOS HUMANOS Y VETERINARIOS II	9.1	NUEVE PUNTO UNO	APROBADA
13	TECNOLOGIA FARMACEUTICA II	8.4	OCHO PUNTO CUATRO	APROBADA
14	LEGISLACION FARMACEUTICA DEONTOLOGIA	8.8	OCHO PUNTO OCHO	APROBADA
15	QUIMICA INDUSTRIAL E INVESTIGACION Y APRO-			
16	VECHAMIENTO DE RECURSOS NATURALES	8.1	OCHO PUNTO UNO	APROBADA
17	QUIMICA AGRICOLA APLICADA IV	9.1	NUEVE PUNTO UNO	APROBADA
18	LA ESCALA DE CALIFICACION ES DE CERO PUNTO CERO (0.0) A DIEZ PUNTO CERO (10.0)			
19	NOTA MINIMA DE APROBACION ES DE SEIS PUNTO CERO (6.0) ESTA CERTIFICACION AMPARA			
20	CUARENTA Y SIETE (47) ASIGNATURAS APROBADAS. Y, PARA LOS USOS QUE CONVENGAN A LA			
21	INTERESADA, SE LE EXTIENDE, FIRMA Y SELLA LA PRESENTE CERTIFICACION GLOBAL DE -			
22	NOTAS, EN LA CIUDAD UNIVERSITARIA, SAN SALVADOR, A LOS DOS DIAS DEL MES DE JULIO			
23	DE MIL NOVECIENTOS NOVENTA Y OCHO.-----			
24	-----			





*C. Adela Muñoz Chávez de Melgar*

1	LICDA. ADELA MUÑOZ CHAVEZ DE MELGAR
2	SECRETARIO DE ASUNTOS ACADEMICOS AD-HONOREM.
3	ELABORO : MIRNA CORADO
4	CONFONTO: MELANI RIVAS
5	RECIBO No. 518744
6	<i>[Signature]</i>
7	
8	
9	El Infrascrito Secretario General de la Universidad de El Salvador
10	CERTIFICA QUE: La firma que aparece al pie de la anterior Certificación
11	GLOVAL DE NOTAS extendida a [REDACTED], es
12	auténtica por haber sido puesta por la LIC. ADELA MUÑOZ CHAVEZ DE MELGAR,
13	Secretario de Asuntos Académicos Ad-Honorem de esta Universidad.
14	Dicho documento está elaborado en dos hoja (s) de papel esp. 532021/ 192121;
15	firmado y sellado por el suscrito Secretario General de La Universidad de
16	El Salvador.
17	San Salvador, a los once días del mes de noviembre de mil
18	novecientos noventa y ocho.
19	<i>[Signature]</i>
20	ENRIQUE ARIUNO LUNA
21	SECRETARIO GENERAL
22	R.I. 863145
23	<i>[Signature]</i>
24	

Round Stamp

UNIVERSITY OF EL SALVADOR

1998

Round Stamp  
University of El Salvador

1998

N° 532021

FIFTY CENTS

1. THE UNDERSIGNED AD HONOREM SECRETARY OF ACADEMIC AFFAIRS, FROM THE UNIVERSITY  
2. OF EL SALVADOR, CERTIFIES THAT: [REDACTED], STUDIED AND PASSED  
3. IN THIS UNIVERSITY SINCE THE ACADEMIC YEAR OF 1986 - 1987, TO THE ACADEMIC YEAR  
4. 1990 - 1991 THE CURSES DETAILED BELOW, IS CURRENTLY GRADUATED IN THE  
5. BACHELOR DEGREE OF **CHEMISTRY AND PHARMACY.**

6. ACADEMIC YEAR 1986-1987 SEMESTER I

7.	ENGLISH I	8.9	EIGHT POINT NINE	PASS
8.	GENERAL CHEMISTRY	8.8	EIGHT POINT EIGHT	PASS
9.	PHYSICS I	9.1	NINE POINT ONE	PASS
10.	MATHEMATICS I	9.4	NINE POINT FOUR	PASS

11. ACADEMIC YEAR 1986-1987 SEMESTER II

12.	GENERAL CHEMISTRY II	8.8	EIGHT POINT EIGHT	PASS
13.	MATHEMATICS II	9.7	NINE POINT SEVEN	PASS
14.	PHYSICS II	9.6	NINE POINT SIX	PASS
15.	ENGLISH II	8.0	EIGHT POINT CERO	PASS
16.	RESEARCH AND WRITING TECHNIQUES	9.2	NINE POINT TWO	PASS

17. ACADEMIC YEAR 1987-1988 SEMESTER I

18.	MATHEMATICS III	9.2	NINE POINT TWO	PASS
19.	INORGANIC CHEMISTRY I	7.8	SEVEN POINT EIGHT	PASS
20.	ORGANIC CHEMISTRY I	8.5	EIGHT POINT FIVE	PASS
21.	ANALYTICAL CHEMISTRY I	8.1	EIGHT POINT ONE	PASS

22. ACADEMIC YEAR 1987-1988 SEMESTER II

23.	ORGANIC CHEMISTRY II	6.5	SIX POINT FIVE	PASS
24.	ANALYTICAL CHEMISTRY II	7.6	SEVEN POINT SIX	PASS

1.	GENERAL BIOLOGY	8.3	EIGHT POINT THREE	PASS
2.	STATISTICS	7.7	SEVEN POINT SEVEN	PASS
3.	GENERAL SOCIOLOGY	8.7	EIGHT POINT SEVEN	PASS
4.	ACADEMIC YEAR 1988-1989 SEMESTER I			
5.	ORGANIC CHEMISTRY III	7.5	SEVEN POINT FIVE	PASS
6.	PSYCHOLOGY APPLIED TO BUSINESS	9.3	NINE POINT THREE	PASS
7.	PHYSICAL CHEMISTRY I	6.7	SIX POINT SEVEN	PASS
8.	GENERAL BIOCHEMISTRY	7.8	SEVEN POINT EIGHT	PASS
9.	ZOOLOGY AND ZOOLOGY APPLIED TO PHARMACY	8.0	EIGHT POINT CERO	PASS
10.	ACADEMIC YEAR 1988-1989 SEMESTER II			
11.	PHYSICAL CHEMISTRY II	7.9	SEVEN POINT NINE	PASS
12.	ANATOMY	8.6	EIGHT POINT SIX	PASS
13.	MICROBIOLOGY AND PARASITOLOGY	8.5	EIGHT POINT FIVE	PASS
14.	BOTANICS AND PHARMACEUTICAL BOTANICS	8.5	EIGHT POINT FIVE	PASS
15.	MANAGEMENT	7.6	EVEN POINT SIX	PASS
16.	ACADEMIC YEAR 1989-1990 SEMESTER I			
17.	PHARMACOCHEMISTRY	7.8	NINE POINT ONE	PASS
18.	PHYSIOLOGY	8.4	EIGHT POINT FOUR	PASS
19.	PHARMACOGNOSY	8.0	EIGHT POINT CERO	PASS
20.	ORGANIC CHEMISTRY III	8.7	EIGHT POINT SEVEN	PASS
21.	APPLIED AGRICULTURAL CHEMISTRY I	8.6	EIGHT POINT SIX	PASS
22.	ACADEMIC YEAR 1989-1990 SEMESTER II			
23.	BROMATOLOGICAL ANALYSIS	8.3	EIGHT POINT THREE	PASS
24.	PHARMACOTECHNY	8.7	EIGHT POINT SEVEN	PASS

GO TO PAGE No. 192121

Round Stamp

FROM SHEET No 582021

UNIVERSITY OF EL SALVADOR

1998

Round Stamp  
University of El Salvador

1998

N° 192121

FIFTY CENTS

1.	PHARMACOLOGY	9.0	NINE POINT CERO	PASS
2.	APPLIED AGRICULTURAL CHEMISTRY II	9.6	NINE POINT SIX	PASS
3.	ACADEMIC YEAR 1990-1991 SEMESTER I			
4.	QUALITY CONTROL OF HUMANS AND			
5.	VETERINARY PHARMACEUTICAL PRODUCTS I	8.1	EIGHT POINT ONE	PASS
6.	PHARMACEUTICAL TECHNOLOGY I	8.6	EIGHT POINT SIX	PASS
7.	LEGAL CHEMISTRY AND TOXICOLOGICAL ANALYSIS	8.3	EIGHT POINT THREE	PASS
8.	ENVIRONMENTAL POLLUTION AND PUBLIC HEALTH	7.7	SEVEN POINT SEVEN	PASS
9.	APPLIED AGRICULTURAL CHEMISTRY	9.1	NINE POINT ONE	PASS
10.	ACADEMIC YEAR 1990-1991 SEMESTER II			
11.	QUALITY CONTROL OF HUMANS AND			
12.	VETERINARY PHARMACEUTICAL PRODUCTS II	9.1	NINE POINT ONE	PASS
13.	PHARMACEUTICAL TECHNOLOGY II	8.4	EIGHT POINT FOUR	PASS
14.	PHARMACEUTICAL DEONTOLOGY LEGISLATION	8.8	EIGHT POINT EIGHT	PASS
15.	INDUSTRIAL CHEMISTRY RESEARCH AND			
16.	MANAGEMENT OF NATURAL RESOURCES	8.1	EIGHT POINT ONE	PASS
17.	APPLIED AGRICULTURAL CHEMISTRY IV	9.1	NINE POINT ONE	PASS
18.	THE GRADING SCALE IS FROM CERO POINT CERO (0.0) TO TEN POINT CERO (10.0).			
19.	THE MINIMUM PASSING GRADE IS SIX POINT CERO (6.0) THIS GRADE INCLUDES			
20.	FORTY-SEVEN PASS SUBJECTS, FOR THE USES DEEMS APPROPRIATE TO THE STUDENT,			
21.	IT ISSUES, SIGNS AND STAMPS THIS OFFICIAL TRANSCRIPT. IN THE UNIVERSITY			
22.	CITY, SAN SALVADOR, ON THE SECOND DAY OF JULY NINETEEN NINETY-EIGHT.			
23.	-----			
24.	-----			

*Round Stamp*

1. *Signature*

2. LICDA.ADELA MUÑOZ CHAVEZ DE MELGAR

3. AD-HONOREM SECRETARY OF ACADEMIC AFFAIRS

4. ELABORATED BY: MIRNA COLORADO *Signature*

5. CONFRONTED BY: MELANY RIVAS *Signature*

6. RECEIPT No 518744

7. *Signature*

9. The Undersigned Secretary of Academic Affairs, from the University of El Salvador

10. CERTIFIES THAT: the signature appearing at the bottom of the above GLOBAL

11. CERTIFICATE OF GRADES issued [REDACTED], is

12. authentic for it has been issued by LIC. ADELA MUÑOZ CHAVEZ DE MELGAR,

13. - Ad Honorem Secretary of Academic Affairs from this University.

14. This document is elaborated using two sheets of security paper 532021/ 192121;

15. signed and sealed by the undersigned general secretary of the University

16. of El Salvador.

17. San Salvador, on the eleventh day of November

18. nineteen ninety-eight.

19. *Signature*

20. ENNIO ARTURO LUNA

21. GENERAL SECRETARY

22. R.D 863145

23.

24.



University Diplomas

# North Stanly High School

Stanly County



North Carolina

This Certifies That

Tommy Allen Thompson

Has satisfactorily completed a Course of Study prescribed for Graduation  
from this School and is therefore awarded this

## Diploma

Given in the month of June, Nineteen hundred and eighty-six

*J. E. Martin*  
Superintendent

*Daniel E. Massey*  
Principal

# Escuela Secundaria North Stanly

Condado de Stanly



Carolina del Norte

Certifica que

**Tommy Allen Thompson**

Ha completado satisfactoriamente el programa de estudios necesario para graduarse de esta Escuela y, por lo tanto, se le otorga el presente

**Diploma**

Dado en el mes de junio de mil novecientos ochenta y seis.

*Firma*

Superintendente

*Firma*

Director

## Marriage certificate

### MODELO DE UN PARTIDA DE MATRIMONIO.

Partida Numero \_\_\_\_\_  
nombre \_\_\_\_\_  
de \_\_\_\_\_ años de edad,  
estado civil \_\_\_\_\_  
ocupación u oficio \_\_\_\_\_  
originario de \_\_\_\_\_  
del domicilio de \_\_\_\_\_  
de nacionalidad \_\_\_\_\_  
hijo de \_\_\_\_\_  
y \_\_\_\_\_  
de \_\_\_\_\_ años de edad,  
estado civil \_\_\_\_\_  
ocupación u oficio \_\_\_\_\_  
originaria de \_\_\_\_\_  
del domicilio de \_\_\_\_\_  
de nacionalidad \_\_\_\_\_  
hija de \_\_\_\_\_  
y \_\_\_\_\_  
contrajeron matrimonio civil, ante los oficios \_\_\_\_\_  
a presencia de los testigos: \_\_\_\_\_  
el día \_\_\_\_\_  
régimen patrimonial \_\_\_\_\_  
Alcaldía Municipal: \_\_\_\_\_ del dos mil \_\_\_\_\_

**MARRIAGE CERTIFICATE SAMPLE**

Marriage Certificate Number \_\_\_\_\_  
full name \_\_\_\_\_,  
at \_\_\_\_\_ years of age  
marital status \_\_\_\_\_  
occupation \_\_\_\_\_  
originally from \_\_\_\_\_  
current address \_\_\_\_\_  
nationality \_\_\_\_\_  
son of \_\_\_\_\_  
and \_\_\_\_\_,  
at \_\_\_\_\_ years of age  
marital status \_\_\_\_\_  
occupation \_\_\_\_\_  
originally from \_\_\_\_\_  
current address \_\_\_\_\_  
nationality \_\_\_\_\_  
daughter of \_\_\_\_\_  
and \_\_\_\_\_,  
join in lawful wedlock, before the official of \_\_\_\_\_  
in the presence of the witnesses: \_\_\_\_\_  
dated this \_\_\_\_\_ day of \_\_\_\_\_ in the year \_\_\_\_\_  
matrimonial property regime \_\_\_\_\_  
City Hall: \_\_\_\_\_ in the year \_\_\_\_\_

\_\_\_\_\_  
**Chief of the Family Status Register**



## MEMORANDUM OF AGREEMENT

This Memorandum of Agreement (MOA) is entered into this day, Friday 20<sup>th</sup> August 2015, by and between **FACULTY OF TECHNOLOGY AND VOCATIONAL EDUCATION (FTVE), UNIVERSITAS PENDIDIKAN INDONESIA, (BANDUNG, WEST JAVA, INDONESIA)** and **FACULTY OF ENGINEERING (FOE), UNIVERSITI SELANGOR (SELANGOR, MALAYSIA)**.

**WHEREAS** the two parties agree to establish affiliation and cooperation in specific areas mutually beneficial and agreeable by all parties concerned in the near future.

**WHEREAS** the collaboration between these institutions is proposed to enhance the material, physical and intellectual development of the students, faculty members, and staffs of the collaborating institutions; to complement each institution's need in business/industry practice with the academic theory building.

**NOW THEREFORE** the two parties concerned wish to establish the following Memorandum of Agreement (MOA) which shall lead to the signing of a Memorandum of Agreement (MOA) subsequently containing matters, but not limited to, the following:

### Article 1

#### **The institutions resolve to exercise reasonable efforts to:**

- (a) Promote exchange of academic personnel for teaching, research, or both in areas mutually beneficial;
- (b) Academic programs curricula joint-setting at the diploma, bachelor's degree or master's degree in specific areas mutually beneficial to all parties concerned;
- (c) Promote internships or temporary employment of students at the areas required by business/industrial institution in cooperation.
- (d) Conduct in house training and workshops for business/industrial institution for academic theory building and development;
- (e) Promote research execution in business/industrial institution of academic theory building and development;



- (f) Promote cooperation of materials and resources for the academic program;
- (g) Consider organizing joint seminars and or conference in areas mutually agreeable;
- (h) Promote joint research and publication in specific areas mutually beneficial; and
- (i) Promote others forms of cooperation mutually agreeable by the parties concerned from time to time.

## **Article 2**

### **Nature of cooperation:**

This cooperation encompasses the area in exchanging business/industry professionals/practitioners training, joint-curricula setting, student internships, and faculty members in academic programs, administration, teaching, research, and development, and cultural affiliation.

## **Article 3**

### **Curriculum:**

All parties concerned will work together in developing the applicable academic curriculum in specific areas mutually agreed, and outlined ultimately in the Memorandum of Agreement (MOA).

## **Article 4**

### **Faculty Member & Business/Industry Practitioner:**

All parties concerned will promote and conduct exchange of academic & Business/Industry practitioner as well as related personnel, taking into consideration the specific needs of either party and mutually agreed by all parties.

## **Article 5**

### **Academic Programs:**

All parties concerned will retain full control and authority on academic matters or business/industry code of conduct in their respective degree, diploma programs, and positions in business/industrial institutions, however, amendments and customizations to meet regulatory compliance shall be done with mutual consent of the parties involved.

## Article 6

### **Finance:**

All parties concerned shall specify the financial implications (training or internship fees, et cetera) of the collaboration in the Memorandum of Agreements Mutually agreed by both parties.

## Article 7

### **Confidentiality:**

1. Each Party shall undertake to observe the confidentiality and secrecy of documents, information and other data received from or supplied to, the other Party during the period of the implementation of this Memorandum of Agreement or any other agreements made pursuant to this Memorandum of Agreement.
2. For purposes of paragraph 1 above, such documents, information and data include any documents, information and data which is disclosed by a Party (the Disclosing party) to the other Party (the Receiving party) prior to, or after, the execution of the Memorandum of Agreement, involving technical, business, marketing, policy, know-how, planning, project management and other documents, information, data and/or solutions in any form, including but not limited to any document, information or data which designated in writing to be confidential or by its nature intended to be for the knowledge of the Receiving party or if orally given, is given in the circumstances of confidence.
3. Both Parties agree that the provisions of this Article shall continue to be binding between the parties notwithstanding the termination of this Memorandum of Agreement.

## Article 8

### **Effect of Memorandum of Agreement:**

This Memorandum of Agreement serves only as a record of the Parties' intentions and does not constitute or create, and is not intended to constitute or create, obligations under domestic or international law and will not give rise to any legal process and will not deemed to constitute or create any legally binding or enforceable obligations, express or implied.

## Article 9

### **No agency:**

Nothing contained herein is to be constituted as a joint venture partnership or formal business organization of any kind between the Parties or so to constitute either Party as the agent of the other.

**Article 10**

**Duration and Termination:**

1. This Memorandum of Agreement (MOA) shall be effective upon the date of signature by the appropriate representatives of both institutions and shall be valid for a period of **5 (Five) years**.
2. Either Party may terminate this Memorandum of Agreement (MOA) at any time by giving ninety (90) days prior written notice to the other Party.
3. Termination of this Memorandum of Agreement (MOA) shall not affect any other commitment or arrangement made prior to termination.

SIGNED for and on behalf :  
**FACULTY OF TECHNOLOGY AND  
VOCATIONAL EDUCATION (FTVE),  
UNIVERSITAS PENDIDIKAN  
INDONESIA, (BANDUNG, WEST JAVA,  
INDONESIA)**

.....  
**(ASSOC. PROF DR AGUS SETIAWAN)**  
(Dean)

In the presence of :

.....  
**(ASSOC. PROF DR BUDI MULYANTI)**  
(Head of Department Electrical  
Engineering)

Date: 20<sup>th</sup> August 2015

SIGNED for and on behalf :  
**FACULTY OF ENGINEERING,  
UNIVERSITI SELANGOR,  
SELANGOR, MALAYSIA**

.....  
**(ASSOC. PROF DR SALINA BINTI  
MUHAMMAD)**  
Dean

In the presence of :

.....  
**(MR. OJO KURDI)**  
(Lecturer of Department Mechanical  
Engineering)

Date: 20<sup>th</sup> August 2015

## **MEMORÁNDUM DE ACUERDO**

El presente Memorándum de Acuerdo (MDA) se realizó este día, viernes 20 de agosto de 2015, entre la **FACULTAD DE TECNOLOGÍA Y EDUCACIÓN VOCACIONAL (FTEV)**, la **UNIVERSIDAD DE EDUCACIÓN DE INDONESIA, (BANDUNG, WEST JAVA, INDONESIA)** y la **FACULTAD DE INGENIERÍA (FDE), UNIVERSIDAD DE SELANGOR (SELANGOR, MALASIA)**.

**CONSIDERANDO QUE** ambas partes involucradas han acordado establecer la afiliación y la cooperación en áreas específicas de beneficio mutuo y acordadas por las partes interesadas en un futuro próximo.

**CONSIDERANDO QUE** la colaboración entre estas instituciones se propone para mejorar el desarrollo material, físico e intelectual de los estudiantes, los miembros de cada facultad y el personal de las instituciones colaboradoras; complementar la necesidad de cada institución en la práctica empresarial/ industrial con la construcción de la teoría académica.

**POR LO TANTO, AHORA** las dos partes interesadas desean establecer el siguiente Memorándum de Acuerdo (MDA) que dará lugar a la firma de dicho acuerdo, el cual contendrá posteriormente asuntos, pero no se limita a lo siguiente:

### **Artículo 1**

**Las instituciones se comprometen a realizar esfuerzos necesarios para:**

- (a) Promover el intercambio de personal académico para la enseñanza, la investigación o ambas en áreas de beneficio y mutuo acuerdo;
- (b) La fijación conjunta de programas académicos como diplomados, licenciaturas o maestrías en áreas específicas de beneficio mutuo para todas las partes interesadas;
- (c) Promover pasantías o empleos temporales, para estudiantes en las áreas requeridas por la institución empresarial/ industrial en cooperación.
- (d) Realización de capacitación interna y talleres para instituciones empresariales/ industriales para la construcción y el desarrollo de la teoría académica;
- (e) Promover la ejecución de investigaciones en las instituciones empresariales /industriales para la construcción y desarrollo de la teoría académica;



- (f) Promover la cooperación de materiales y recursos para el programa académico;
- (g) Considerar la posibilidad de organizar seminarios conjuntos y/o conferencias en áreas de mutuo acuerdo;
- (h) Promover la investigación y la publicación en conjunto en áreas específicas de mutuo beneficio; y
- (i) Promover otras formas de cooperación de mutuo acuerdo por las partes interesadas de forma ocasional.

## **Artículo 2**

### **Naturaleza de la cooperación:**

Esta cooperación comprende el área de intercambio de negocios/industrias profesionales/practicantes, la configuración de planes de estudio conjuntos, pasantías estudiantiles y miembros de la facultad en programas académicos, administración, enseñanza, investigación y desarrollo, y afiliación cultural.

## **Artículo 3**

### **Plan de estudios:**

Todas las partes interesadas trabajarán en conjunto en el desarrollo del plan curricular aplicable en áreas específicas de beneficio mutuo y señaladas en última instancia en el Memorándum de Acuerdo (MDA).

## **Artículo 4**

### **Miembro de la facultad y Profesional de negocios/industria:**

Todas las partes interesadas promoverán a los profesionales de los negocios/industria, así como personal relacionado, teniendo en cuenta las necesidades específicas de cualquiera de las partes y mutuamente acordadas por todas las partes.

## **Artículo 5.**

### **Programas Académicos**

Todas las partes interesadas conservarán el control total y la autoridad sobre los asuntos académicos o el código de conducta empresarial/ industrial en sus respectivos grados, programas de diploma y puestos en instituciones comerciales/industriales, sin embargo, las enmiendas y personalizaciones para cumplir con el cumplimiento normativo se realizarán con el consentimiento mutuo de las partes involucradas.



## **Artículo 6**

### **Finanzas:**

Todas las partes interesadas deberán especificar las implicaciones financieras (honorarios de formación o pasantías, etc.) de la colaboración en el Memorandum de Acuerdos mutuamente acordado por ambas partes.

## **Artículo 7**

### **Confidencialidad:**

1. Cada parte se comprometerá a respetar la confidencialidad y el secreto de los documentos, la información y otros datos recibidos de la otra parte o suministrados a la otra parte durante el período de aplicación de este Memorando de Acuerdo o cualquier otro acuerdo celebrado de conformidad con este Memorando de Acuerdo.
2. Para los fines del párrafo 1 anterior, dichos documentos, información y datos incluyen cualquier documento, información y datos que una Parte (la Parte Reveladora) revele a la otra Parte (la Parte Receptora) antes o después de la ejecución del Memorando de Acuerdo, que involucre aspectos técnicos, comerciales, de marketing, de política, de conocimientos técnicos, de planificación, de gestión de proyectos y otros documentos, información, datos y/o soluciones en cualquier forma, incluyendo pero no limitado a cualquier documento, información o datos que se designen por escrito como confidenciales o por su naturaleza destinados a ser del conocimiento de la Parte Receptora o si se dan oralmente, se dan en las circunstancias de confidencialidad.
3. Ambas partes acuerdan que las disposiciones de este Artículo continuarán siendo vinculantes entre las partes sin perjuicio de la terminación de este Memorando de Acuerdo.

## **Artículo 8**

### **Efecto del Memorandum de Acuerdo:**

El presente Memorandum de Acuerdo sirve únicamente para dejar constancia de las intenciones de las Partes y no constituye ni crea, y no tiene la intención de constituir o crear, obligaciones en virtud del derecho nacional o internacional y no dará lugar a ningún proceso legal ni se considerará que constituye o crea ninguna obligación legalmente vinculante o exigible, expresa o implícita.

## **Artículo 9**

### **Sin agencia:**

Nada de lo contenido en este documento debe constituirse como una sociedad conjunta u organización comercial formal de cualquier tipo entre las Partes o para constituir a cualquiera de las Partes como el agente de la otra.

## Artículo 10

### Duración y Terminación

1. Este Memorándum de Acuerdo (MOA) entrará en vigor en la fecha de la firma por los representantes correspondientes de ambas instituciones y será válido por un período de **5 (cinco) años**.
2. Cualquiera de las Partes puede rescindir el presente Memorando de Acuerdo (MOA) en cualquier momento, mediante una notificación por escrito a la otra Parte con 90 (noventa) días de anticipación.
3. La terminación del presente Memorando de Acuerdo (MOA) no afectará ningún otro compromiso o acuerdo realizado antes de la terminación.

FIRMADO por y en nombre:  
**FACULTAD DE TECNOLOGÍA Y  
FORMACIÓN PROFESIONAL (FTVE)<sup>1</sup>,  
UNIVERSIDAD DE EDUCACIÓN DE  
INDONESIA, (BANDUNG, JAVA  
OCCIDENTAL, INDONESIA)**

*Firma*

.....  
**(ASSOC. PROF DR AGUS SETIAWAN)**  
(Decano)

En presencia de:

*Firma*

.....  
**(ASSOC. PROF DR BUDI MULYANTI)**  
(Jefe de Departamento de Ingeniería  
Eléctrica)

Fecha: 20 de agosto de 2015

FIRMADO por y en nombre:  
**FACULTAD DE INGENIERÍA,  
UNIVERSIDAD DE SELANGOR,  
SELANGOR, MALASIA**

*Firma*

.....  
**(ASSOC. PROF DR SALINA BINTI  
MUHAMMAD)**  
(Decano)

En presencia de:

*Firma*

.....  
**(MR. OJO KURDI)**  
(Profesor del departamento de  
ingeniería)

Fecha: 20 de agosto de 2015

<sup>1</sup>**FTVE** por sus siglas en inglés.  
(N. del T. n)

## CONCLUSIONS

### **Argumentative essay**

Have you ever heard that anyone who knows two languages can translate a text from one language to another? Is it that easy to do good translations, what do you think? Is someone a translator by the mere fact of knowing two languages?

The work of a translator is very complex, and often, we do not realize all the work involved when translating an extensive text. It is becoming increasingly clear that a good translation must convey the same content of the source text to the target language, and obviously, it must not add or delete ideas. The register of the source text, the idioms, and the terminology must be translated correctly. And since the text was created for a specific purpose and audience, they must be respected, so that the translation will have the same effect. Therefore, as Spanish is our mother tongue, our efforts to translate into Spanish will be minor since we have greater knowledge of the vocabulary, and we are also familiar with its grammatical structures.

Translating is a complex process in which the translator must study the original text and the type of audience to which the translation is addressed since they will be our basis and our starting point during this process. This doesn't mean that just because we have knowledge of another language, we are good translators. Moreover, good analytical work and subsequent revision are required to obtain a coherent and natural translation, in the target language.

The translation process is a point of approach that goes beyond borders, focused on the need to unite two different cultures, despite their political, social, cultural, and economic differences. It is the work where we are all one, communicating from one continent to another without restrictions and respecting the realities and ideas. Ethics within this work is very important since our personal opinions and ideas should not interfere in the translation. Our job as future translators is to translate the information we have in a certain language to another, without alterations of any kind even if we do not agree with what is expressed within it. Otherwise, we could not rely on information from other countries and would limit ourselves to knowledge. In the field of education, for example, children can

receive richer and more comprehensive knowledge from around the world, and they can learn to compare and discuss different perspectives.

In countries with many foreign language speakers (caused by immigration, for example) translation can help with the integration of those people into the society. Can you imagine how uncomfortable it can be living in a new country where you don't understand the language and even your parents don't understand so they cannot help you? However, if all your schoolbooks and the things that surround you are translated into your native language, surely you can better adjust to your new life.

The translation opens up millions of new sources. It grants access to a variety of worldviews with expert opinions from countries and cultures other than our own. Furthermore, it supports critical thinking to understand what others have to say. Discovering what's happening in different countries through our language, thus staying informed about the world.

Since our society relies on translation, our job will be essential for the progress in our own country, otherwise, we would all be much worse off if it wasn't for it. The vast treasures lost would not only be cultural but also material.

Translations of great works will remain as a reminder of a specific period in history, thus enriching our knowledge of the habit of reading, while the informative texts will be modified over time, due to the constant evolution in the critical and analytical thinking of society.

With all the information presented above, it has been concluded that not everyone can translate properly. A computer could never have this capacity for intercultural adaptation, so human intervention is indisputably necessary. The work of a translator is much more important than you think, the updates of information from other sources are thanks to their hard work.

*“Being a translator means to exercise the noble profession of communicating societies separated by language barriers, totally or partially insurmountable for them.”*

-Valentin Garcia Yebra

## RECOMMENDATIONS

✓ It is important to keep in mind that the translation process is a task that requires time and dedication since it is expected to have the same naturalness as the source language.

✓ To understand clearly, the use of translation tools will only work as support resources will facilitate such a process where still human intervention will be needed to fine-tune details and give naturalness to the text. A machine will never replace the originality of the human being.

✓ Once the original text has been read in its entirety, an internet search should be conducted about the main subject of the text to be translated, as this could help us better understand the complexity of the subject and the specific vocabulary used within it.

✓ Every proper name of a place or institution must be verified, through an internet search since not all have an official version adapted to the target language, so it will not always be possible to make these types of changes.

✓ The search for unknown terms must be executed thoroughly since it is expected that different types of virtual dictionaries will be used and select the most accurate option within our text. Try to avoid relying on the first result you find in a dictionary. Remember that everything changes in a specific context.

✓ Within the translation, it is vitally important to check the correct spelling of the words, as well as the respective punctuation marks, as these elements provide seriousness and importance in your final translation. Keep in mind, the position of a comma can change the sense of a complete idea.

✓ Use as many image processors as possible if you want to translate the text within them. Each of them has advantages and disadvantages, so make the most of what each of them has to offer, do not limit yourself to the use of the technological tools that you have in your hands.



✓ Be careful with the quality of images when working with the text embedded within them, the quality must be equal to their original version or even higher.

✓ Avoid modifying the tone of each text, because each of them has a specific purpose, and our function as future translators is to maintain its original format but in a different language.

✓ Do not underestimate the translation process of a text, even when we have advanced English skills, it doesn't mean our translation is perfect. During the process, many factors interfere and can affect the quality of our work, such as fatigue, pressure, and frustration. For these reasons, it is advisable to revise your job one day after finishing it to be able to review the text with a different perspective and then correct details if it is still required.

✓ In case you get stuck in a sentence that there was no way to translate, you can skip this sentence and move on and come back to it later, to better manage the time, and not spend more time than necessary for the translation process. In a real situation, time is essential if you want to be on time with your delivery with high quality in it.

✓ Enjoy each translation, as you will not only be learning new vocabulary, but you will also be enriching yourself with different types of interesting topics and familiarizing yourself with the vocabulary used in legal documents. You will see that over time you will be able to translate with greater fluency and confidence.

## REFERENCES

- Agency Bilis Translation. (July 30, 2017). "*Translation and Culture, a constructive interdependence*". Retrieved from: <https://bilis.com/en/blog/translation-and-culture-a-constructive-interdependence/>
- Aventina Putranti. (April 2018). "*Modulation: A Translation Method to Obtain Naturalness in Target Language Texts*" (PDF file). Retrieved from: <https://e-journal.usd.ac.id/index.php/JOLL/article/download/1115/886>
- Barbara Johnston (29/ 09/ 2022) "*La importancia de la traducción*" Fitness Latinos <https://fitnesslatinos.com/es/2019/09/29/la-importancia-de-la-traduccion/>
- Encyclopedia Britannica, Inc. (2022). "*People known for Education*". Retrieved from: <https://www.britannica.com/biographies/education/education>
- Fernando A. López. (13 febrero 2019). "*La importancia de la Traducción*". Welum Translations, profesionales de la traducción. Retrieved from: <https://www.weluntranslations.com/post/2019/02/13/la-importancia-de-la-traducci%C3%B3n>
- Jenny Brunne. (2020). "*Traducción de la cultura*". Universitat Pompeu Fabra. Retrieved from: [http://www.ucm.es/info/especulo/ele/trad\\_cul.html](http://www.ucm.es/info/especulo/ele/trad_cul.html)
- Nuria Ponce Márquez. (2007). "*El apasionante mundo del traductor como eslabón invisible entre lenguas y culturas*". *Revista electrónica de Estudios Filológicos*. Retrieved from: [https://www.um.es/tonosdigital/znum13/secciones/tritonos\\_B\\_nuria%20Ponce.htm](https://www.um.es/tonosdigital/znum13/secciones/tritonos_B_nuria%20Ponce.htm)
- Traducciones Agora. (2002-2022). "*Cómo es el proceso de traducción de un documento*". Retrieved from: <https://agorafs.com/como-es-el-proceso-de-traducion-de-un-documento/>
- Translation Services, traveling across cultures. (August 1, 2016). "*Importance of Translation in our Life*". Retrieved from: <https://dubaitranslationservices.ae/importance-translation-life/>
- Wordemy. (November 21, 2016). "*Importance of Language Translation*". Retrieved from: <https://wordemy.com/blog/importance-language-translation/>