

**UNIVERSITY OF EL SALVADOR  
SCHOOL OF ARTS AND SCIENCES  
DEPARTMENT OF FOREIGN LANGUAGES**



**TOPIC:**

**TRANSLATION OF IMAGES, LEGAL AND ACADEMIC DOCUMENTS BY  
FOLLOWING A TRANSLATION PROCESS IN ENGLISH AND SPANISH  
LANGUAGES.**

**PRESENTED BY:**

Karla Elizabeth Nuñez García	(NG15009)
Lourdes Marcela Vasquez Ruiz	(VR16002)
Katherine Gabriela Rosales Aguilar	(RA15086)
Gabriel Eliseo Portillo García	(PG15044)
Valeria Sarai Mejía Anzora	(MA16026)

**INFORME FINAL DE CURSO DE ESPECIALIZACIÓN  
FUNDAMENTALS AND TRANSLATION TECHNIQUES  
IN ORDER TO OBTAIN THE DEGREE OF:  
BACHELOR OF ARTS IN MODERN LANGUAGES  
WITH A MAJOR IN FRENCH AND ENGLISH  
AND  
BACHELOR OF ARTS IN ENGLISH WITH A MAJOR IN LANGUAGE  
TEACHING**

**MASTER CRISTIAN ALEXANDER TORRES MELÉNDEZ  
SPECIALIZATION PROFESSOR**

**BACHELOR MIGUEL ÁNGEL CARRANZA CAMPOS, MSe.  
GENERAL COORDINATOR OF THE GRADUATION PROCESS**

**UNIVERSITY CAMPUS, DR. FABIO CASTILLO FIGUEROA, SAN SALVADOR,  
EL SALVADOR, NOVEMBER 2022**

**AUTHORITIES OF THE UNIVERSITY OF EL SALVADOR**

**RECTOR:**

**MASTER ROGER ARMANDO ARIAS ALVARADO**

**ACADEMIC VICE-RECTOR:**

**PHD. RAÚL ERNESTO AZCÚNAGA LÓPEZ**

**ADMINISTRATIVE VICE-RECTOR:**

**BACHELOR OF ENGINEERING JUAN ROSA QUINTANILLA QUINTANILLA**

**GENERAL SECRETARY:**

**BACHELOR OF ENGINEERING FRANCISCO ANTONIO ALARCÓN  
SANDOVAL**

**AUTHORITIES OF THE SCHOOL OF ARTS AND SCIENCES**

**DEAN:**

**MASTER OSCAR WUILMAN HERRERA RAMOS**

**VICE-DEAN:**

**MASTER SANDRA LORENA BENAVIDES DE SERRANO**

**SECRETARY:**

**MASTER JUAN CARLOS CRUZ CUBIAS**

**AUTHORITIES OF THE DEPARTMENT OF FOREIGN LANGUAGES**

**HEAD OF THE FOREIGN LANGUAGES DEPARTMENT:  
MASTER ANA GRACE GÓMEZ ALEGRÍA**

**GENERAL COORDINATOR OF THE GRADUATION PROCESS:  
BACHELOR MIGUEL ÁNGEL CARRANZA CAMPOS, MSc.**

**SPECIALIZATION PROFESSOR:  
MASTER CRISTIAN ALEXANDER TORRES MELÉNDEZ**

## INDEX

<b>1. ABSTRACT .....</b>	<b>5</b>
<b>2. INTRODUCTION .....</b>	<b>6</b>
2.1 Introduction .....	6
2.2 The importance of the translation .....	7
<b>3. TRANSLATION PROCESS .....</b>	<b>9</b>
3.1 Concept of Translation Process .....	9
3.2 The Translation Process MindMap .....	10
3.3 Translation Process Explanation .....	10
<b>4. TRANSLATIONS .....</b>	<b>13</b>
4.1 Definition of translation .....	13
4.2 Translation of documents .....	14
Digestive System .....	14
How engines work .....	20
Operation manual mp5 player .....	40
Birth certificates .....	63
University Transcript .....	69
University Diplomas .....	71
Marriage certificate .....	73
<b>5. CONCLUSIONS .....</b>	<b>75</b>
<b>6. RECOMMENDATIONS .....</b>	<b>77</b>
<b>7. REFERENCES .....</b>	<b>78</b>
<b>8. ANNEXES .....</b>	<b>79</b>

## 1. ABSTRACT

The report discusses the definition of the translation process and provides insights into each phase involved, highlighting the challenges and techniques encountered. Additionally, it presents a compilation of the translation projects undertaken during the specialization course, encompassing a diverse range of documents, such as birth certificates, university and high school diplomas, academic transcripts, an article on the digestive system, a user manual for mp5 player, a marriage certificate and an automotive magazine detailing the workings of a Toyota vehicle engine. The translation process entails several interconnected stages. Firstly, a thorough analysis of the source text is conducted to grasp its meaning, intent, and cultural nuances. Following this, appropriate strategies and techniques are employed to ensure accurate transfer of the source text's message into the target language. The subsequent phase involves the actual translation, where linguistic and cultural aspects are considered, and creativity is employed to convey the original meaning effectively. Post-translation, rigorous editing and proofreading are carried out to refine the target text and ensure linguistic coherence and precision. Finally, a quality assessment is conducted to evaluate the fidelity of the translation in comparison to the source text. This report sheds light on the complexities of the translation process and showcases the practical application of acquired skills through a diverse set of translation projects. It underscores the importance of linguistic proficiency, cultural understanding, and attention to detail in achieving accurate and effective translations.

**Keywords:** translation process; linguistic proficiency; cultural understanding; practical skills; diverse documents.

## 2. INTRODUCTION

### 2.1 Introduction

We often have a relative or a friend asking us what the meaning of the lyrics of a song is, or what someone said while watching a video or a movie. More often than not, people will assume that because of our major we will be able to come up with an accurate translation on the spot. However, being fluent in a different language is only the starting point.

Translating is a demanding mental process that requires switching between languages to get an understanding of the source text, choosing appropriate vocabulary, following grammar rules, doing additional research to maintain the style and tone of the source language as well as managing time efficiently. That is why we need specialized training to develop translation skills and gain experience.

Through our Specialization Course in Translation, we first learned the history of translation and its role in the world as the bridge between multiple cultures along with its fundamental concepts and the differences between literal and oblique translations, as well as the translation techniques that can be used for individual words or phrases to achieve the best translation. With this background knowledge, we realized that translating a text means carrying out multiple tasks with different timeframes and degrees of complexity that is why we created our translation process which was customized to help us work as efficiently as possible on our projects.

In addition, we combined our translation process with computer-assisted translation tools (CAT tools) to take our translation work to the next level by improving the consistency, analysis and management of our projects. These tools are helpful to create an initial draft, but cannot replace human translators as they lack naturality since they struggle with understanding emotions and adapting the texts to a specific audience based on their age, academic level, cultural background,

etc.

To be good translators, we need to keep in mind that practice makes perfect. That is why we focused on translating multiple texts from English to Spanish and vice versa throughout this course, which you will find in this portfolio along with our conclusions and some useful recommendations for future translation students.

## **2.2 The importance of the translation**

The translation world is gaining relevance as the time passes, but continues to be a topic that lacks relevance and acknowledgement from society. Indeed, it is more than just changing the words from one language to another. Actually, it helps to build a bridge between cultures around the world to stay in communication. It keeps us closer to those experiences that could be too far from us.

There is a vast number of languages around the world, and we cannot expect to learn each of them or to change our native tongue. So, how can we know about our surroundings? How do we know about the history of languages that no longer exist? The answer is translation, the process that takes a word and transmits in essence and meaning the same purpose as in the source language to the target language, in accordance with the culture of a whole country. The Bible is a great example in the history of translation, which has been translated into approximately 531 different languages. Due to this, a person from France can read it in his/her own native tongue as well as someone from Korea can read the story of Jesus Christ.

Nowadays, there exist different tools that appear to do the same work as a translator. Because of these, people tend to think that translation is an easy task and everyone who barely knows a second language can do it, but those will never convey the feeling and main purpose of the message, or may never show the emotion that each culture has to express in its own way. Certainly, a translator must be skillful not just for changing words, but understanding the language and culture of the source and target language in order to maintain the same meaning in the translated text.

In a modern and diverse world like ours, it is a must to be in constant communication, as it is a basic human need. Our society needs translators because their work is relevant and important in order to share ideas and information in many areas such as literature, media, journalism, business, technology, education, law, among others.

The purpose of translation will always be to create a bridge among people and cultures, so we can share ideas and understand each other without learning a second language. There are 7,000 spoken languages in the current world, and it is not possible to learn them all (Why is Translation Important in Today's World, 2022). It is beneficial to expand our knowledge, so translation exists to incentivize learning. It is crucial to keep in mind that translation is even more complex than just translating words, it needs to be executed by professionals to reach and to develop accurate results when translating. Definitely, translation keeps us connected with our past and will keep us connected with our future.



### 3. TRANSLATION PROCESS

#### 3.1 Concept of Translation Process

The very first record of a translation in human history is the Rosetta Stone dated to 196 BC during the Ptolemaic dynasty. Nevertheless, the translation has evolved substantially with the passing of the centuries. Cronin (2013) argues that “any form of global interaction cannot occur without interlingual activities and thus globalization denotes translation” (Doherty, S. 2016). Given that, the translation process ought to be constantly updated to produce the most accurate translation possible.

The definition of **translation** from the online Collins English Dictionary that literally reads “If something that someone has said or written is translated from one language into another, it is said or written again in the second language.” and subsequently the definition of **process** that literally reads “A process is a series of actions which are carried out in order to achieve a particular result” (Collins. (n.d.). *Definition of “process.”* Retrieved September 25, 2022), the concept of **translation process** would be then: A series of translation strategies, which are followed accordingly to achieve the most accurate translation from the source language into the target language.

### 3.2 The Translation Process MindMap

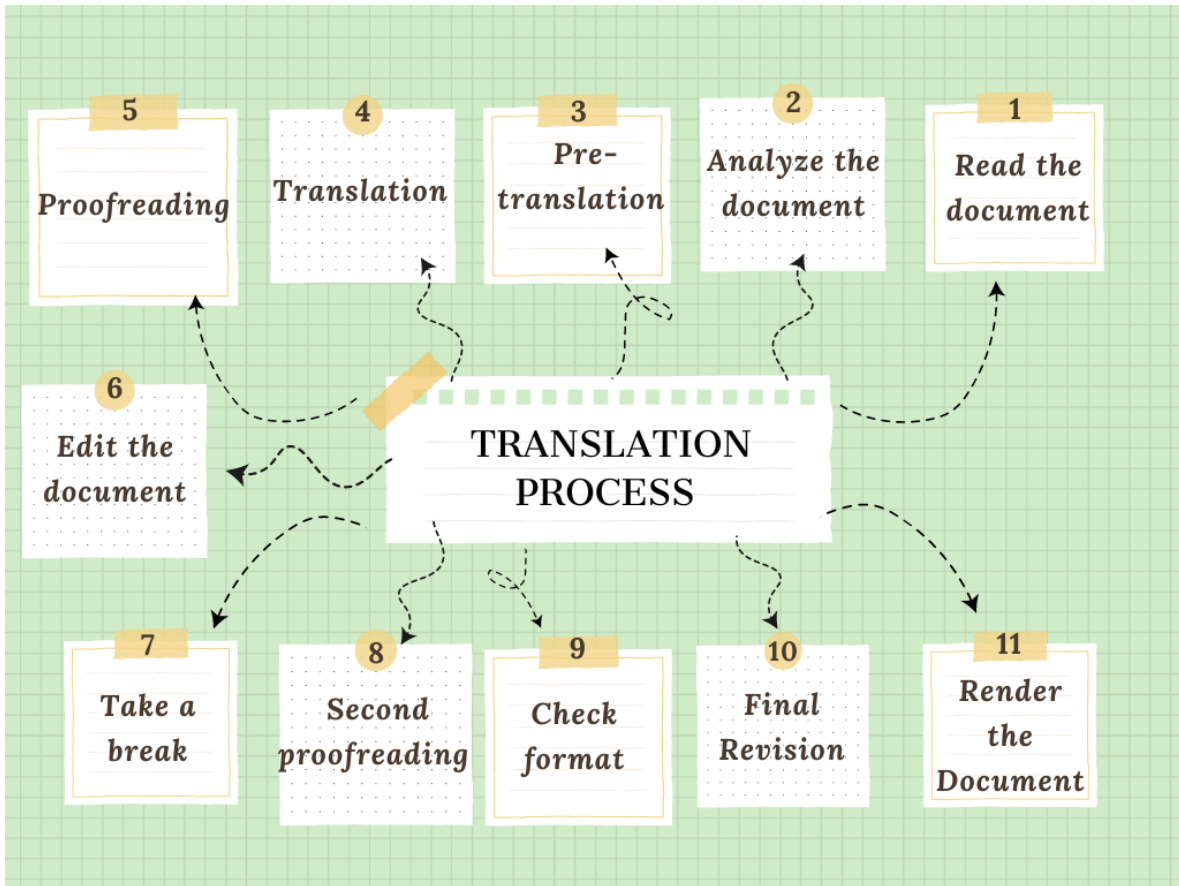

### 3.3 Translation Process Explanation

Considering that the translation process is a series of steps to follow, it should be noted how essential it is to stick to the list below to get the best results.

#### Translation process

- 1. Read the document:** This step will give us an initial idea of the subject, style, and vocabulary to address to the correct target audience. Also, we can do some preliminary research if needed in regards to the topic or vocabulary used in order to do a proper translation.
- 2. Analyze the document:** After the first reading of the text, it is necessary to make a scrutiny of the document. In this step, we may underline and search

the terms and phrases that we do not understand or do not know either in the original language or in the target language.

3. **Pre-translation:** After the steps of reading and searching, we begin with the pre-translation which is the research of the concepts or idioms that are unknown to us. If necessary, a glossary can be created as a helpful tool when translating the document.
4. **Translation:** Here we start translating the original text into the target language, which would be the first draft, using the proper translation techniques. The main objective in this step is to produce a translation in the target language, not minding about the details, but to have a first clear idea about the content. Hence, it is important to take into account the previous investigation made for the translation.
5. **Proofreading:** In this step, we take time to read the first draft as many times as needed and compare the translation between the original text and the translated text.
6. **Edit the document:** After reading the first draft as much as needed, we may identify errors; therefore, we should edit the very first translation and make the corresponding corrections, always being loyal to the original purpose of the text. This is in order to improve the translation, so it looks natural in the target language.
7. **Take a break:** After working a long time in the translation of the text, it is good to take a break. We can get outside of our workspace and do something else to relax. It is important to disconnect ourselves from the translation for a while, then we may come back to continue with the next step.
8. **Second proofreading:** This step is essential to find some possible mistakes that were not noticed before, this thanks to the break that we had taken previously. After correcting errors, we may also compare the original document with the translated text to make sure that everything is accurate.
9. **Check format:** Now that the revision and edition of the translated text is done and no mistakes were found, we can proceed by adapting the format of the translated text according to the original document.

**10. Final revision:** After all this process it is important to read and review our final version of the translated text to avoid any type of error that may affect the quality of the document.

**11. Render the document:** The last step is the release of the document. It is necessary to make sure to use the means previously agreed with the client.

## 4. TRANSLATIONS

### 4.1 Definition of translation

As the world has been spread by cultures and languages, translation has been an important field for mankind as a source of communication in order to maintain cultures joined. In addition, most of the people in the world have been exposed to any type of translation throughout their lives. For example, when someone reads a book of an author who is originally written in French, but the reader only speaks Spanish. That is the reason why translation is very important, so people are able to spread their ideas in other languages.

Our experience during this course has been a journey in which each of us learned from scratch the history of translation and how people often confuse it with interpretation. This one need someone to come up with a not so accurate explanation of what someone is saying on the spot. On the other hand, translation requires more time as the final result is presented in written form; this means that a translator must convey the message from a source text into a target language. To achieve this, a translator must master multiple terms and techniques like: transposition, modulation and adaptation, to name a few.

To translate a text is also important to set a previous translation process that will serve as a guide to set specific timeframes to find the best way to research unknown terminology, when and how to treat an image, as well as finding the best translation tools and techniques to create the best work possible in any field. This is not only about changing words from one language to another, it actually goes further as it is a complex and diverse job that not every person that speaks a second language can execute as it requires its own methodology.

In conclusion, we have experienced as a group this job is indeed a challenging profession, since a translator needs to have specific knowledge to apply, as no one can translate a text when its content is out of their scope. Furthermore, it is fundamental to charge your worth to value the time and effort invested.

## 4.2 Translation of documents

### Digestive System

#### Original Document

258

BIOLOGY

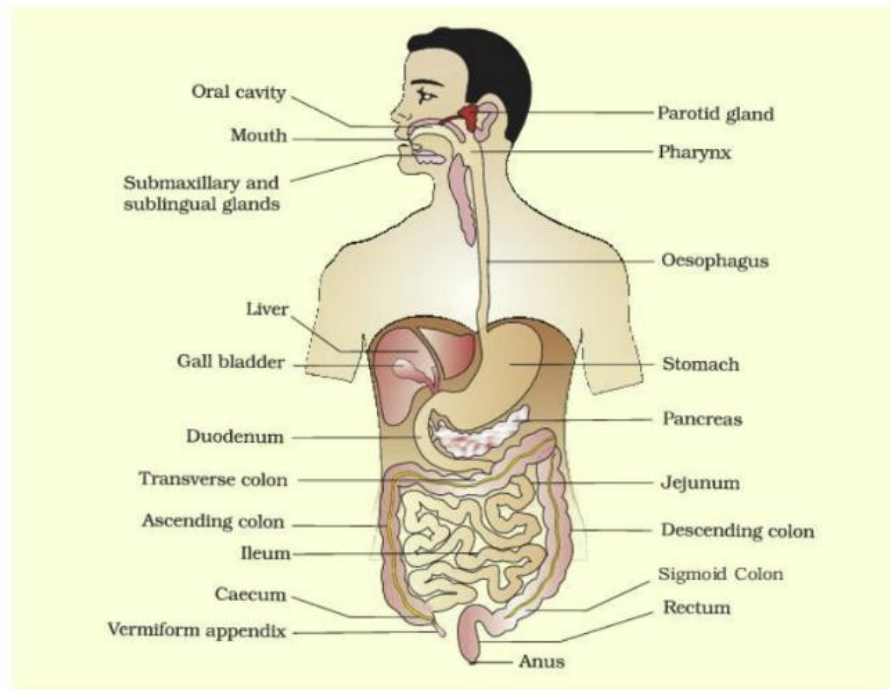

**Figure 16.1** The human digestive system

has 32 permanent teeth which are of four different types (Heterodont dentition), namely, incisors (I), canine (C), premolars (PM) and molars (M). Arrangement of teeth in each half of the upper and lower jaw in the order I, C, PM, M is represented by a dental formula which in human

$$\text{is } \frac{2123}{2123}.$$

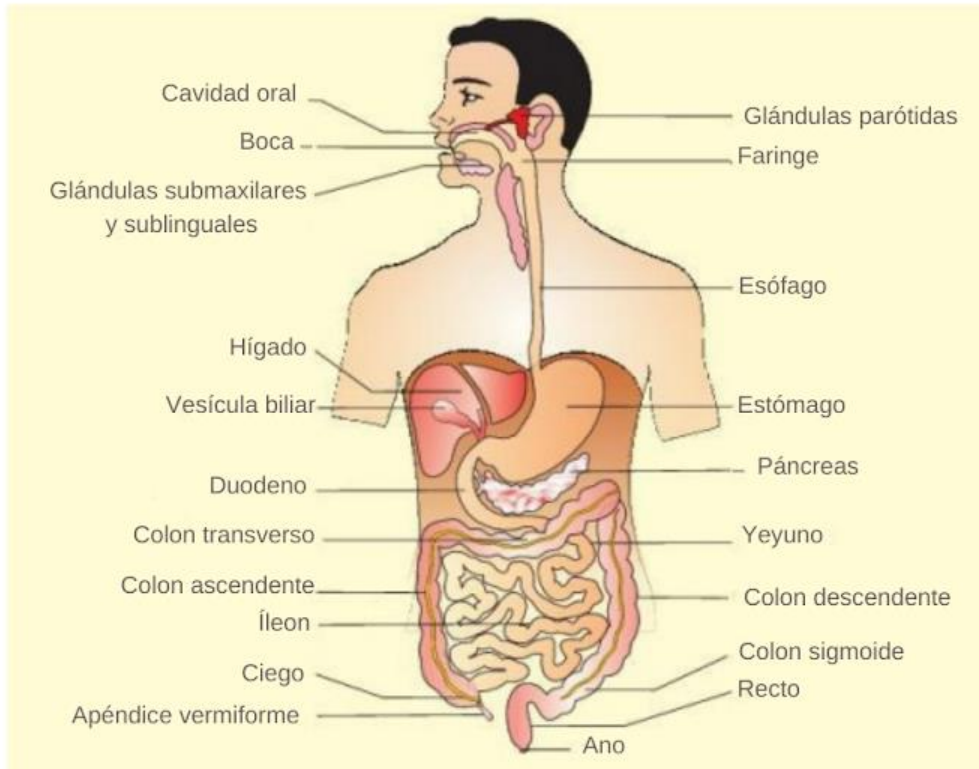

**Figura 16.1** Sistema Digestivo

La cavidad oral posee 32 dientes permanentes que se clasifican en cuatro tipos de dentición heterodonta: incisivos (I), caninos (C), premolares (PM) y molares (M). La distribución de los dientes en la mandíbula superior e inferior siguen el mismo orden I, C, PM, M y se representa por la fórmula dentaria humana  $\frac{2123}{2123}$

## Original Document

The digestive system is one of the most clearly defined in the body.

It consists of a long passageway, the digestive tract, and associated glands.

These include the liver and pancreas, which are connected to the main tract by ducts, or tubes, and empty their products, such as enzymes, into the tract.

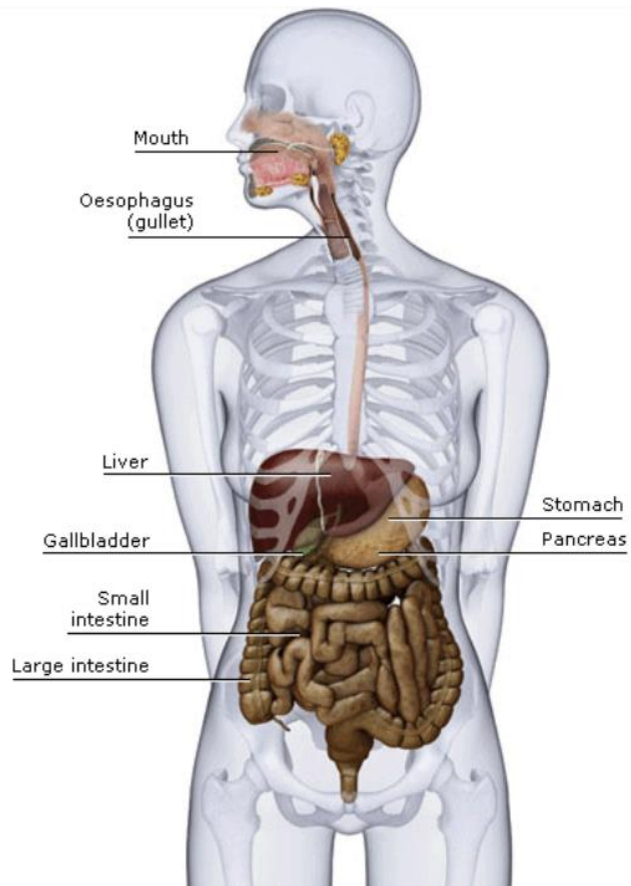



## Translated Document

El sistema digestivo es uno de los mejor definidos en el cuerpo humano.

Está conformado por el tracto digestivo y las glándulas anexas que participan en la digestión.

Estas incluyen el hígado y el páncreas, que están conectados al tracto principal por medio de conductos o tubos que luego liberan sustancias, cómo las enzimas, en el tracto digestivo.

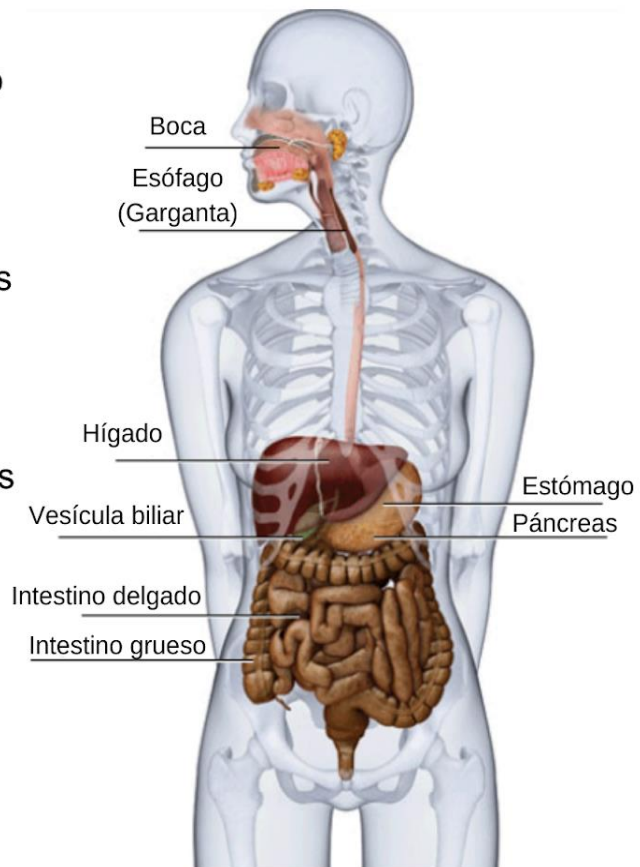

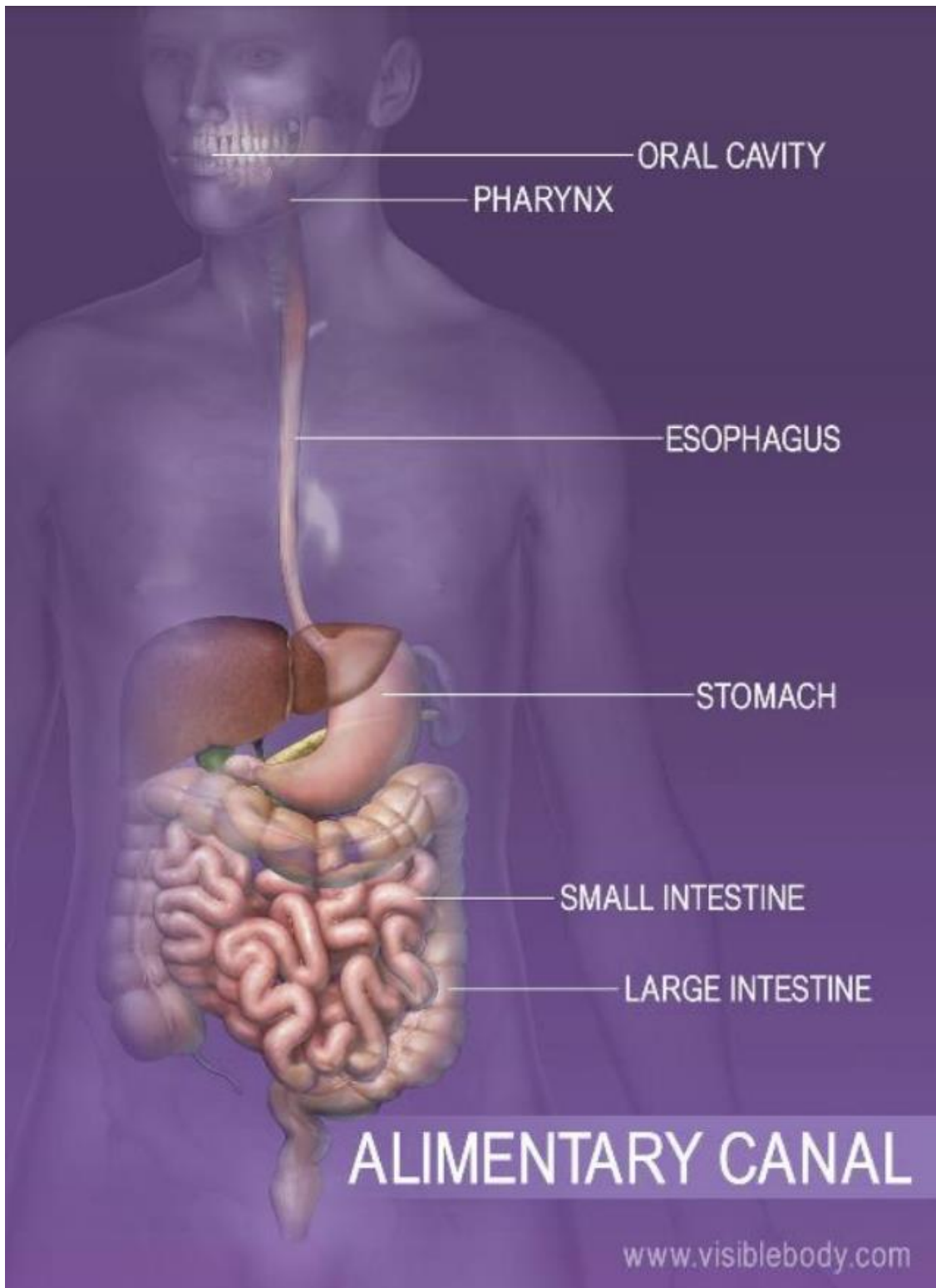





# How engines work

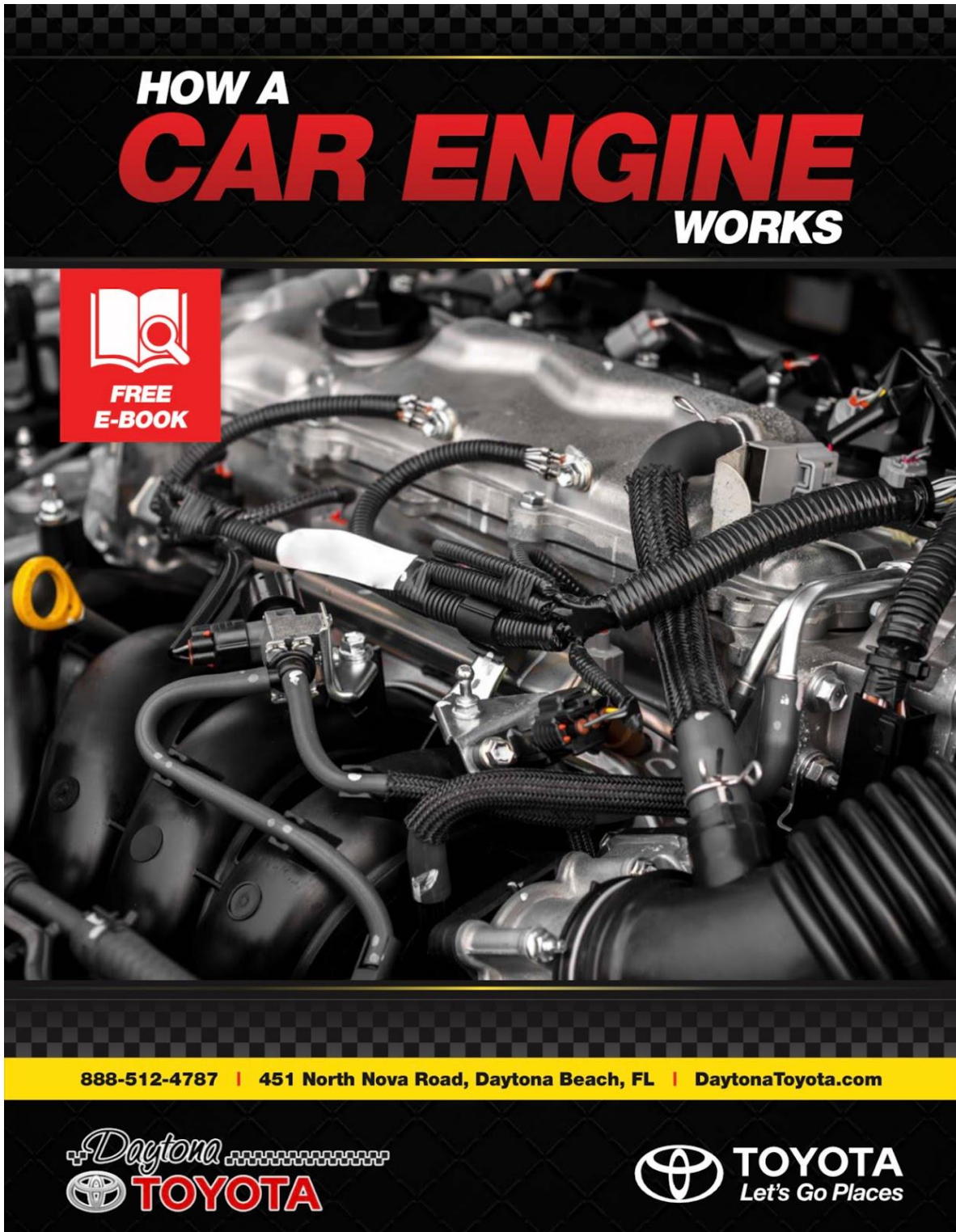

Original Document



**HOW A  
CAR ENGINE  
WORKS**

  
**FREE  
E-BOOK**

888-512-4787 | 451 North Nova Road, Daytona Beach, FL | [DaytonaToyota.com](http://DaytonaToyota.com)

  **TOYOTA**  
Let's Go Places

## HOW A CAR ENGINE WORKS

Every day you rely on your car to get you where you need to be. Just turn the key or press the start button and you're on your way. But how does your car actually work? What makes the engine go so you're able to get on your way?

Keep reading to learn more about what's going on under the hood during your drive.



### *How a Car Engine Works*

Most cars and motor vehicles are powered by what's called an internal combustion engine. It uses the combustible combination of air, fuel, and a single spark to cause a small explosion. This reaction is recreated over and over again by parts that are in a constant rotation.

The first internal combustion engine was invented in 1859 by French engineer J.J. Etienne Lenoir. After nearly 200 years of the steam engine being the peak of modern innovation, he built the first continuously operational gasoline combustion engine.

Its basic principle is to draw in air through an intake valve, then have it enter a cylinder where it's combined with fuel. In most vehicles, that fuel is gasoline. Next, a reaction is created when the spark plugs light this combination. This tiny explosion is what creates the energy that powers your car.

The process is then repeated and the energy that was created leaves the chamber and exits your car through the tailpipe. There are a lot of parts that go into making this work and keeping this rotation going.



## HOW A CAR ENGINE WORKS



### **Parts of an Engine**

An internal combustion engine uses motion to repeat the cycle. While it relies on an explosion to make everything go, the basic idea behind its rotation is similar to that of a steam engine or a water wheel. Some of the key parts are:

- **Engine Block** – This is the foundation for your engine. It's usually made of aluminum alloy or iron. The engine block is the home of your cylinders. All the motion that causes the combustion reaction takes place inside the cylinders. Most cars today feature a 4-cylinder engine, but many are also built with six or eight cylinders for more power.
- **Valves** – Each valve is crucial to moving air through your engine. There's both intake and outtake valves. Usually there's one of each for every cylinder. The valve train is the system that controls when air is brought in and when it's pushed out your exhaust at the end of the cycle.
- **Pistons** – Every one of your cylinders has a piston moving up and down inside it. This solid metal part is at the center of the combustion cycle.
- **Crankshaft** – The crankshaft is attached to the base of each piston by a connecting rod. The motion of the crankshaft is what's used to control when the pistons go up and when they come down.

## HOW A CAR ENGINE WORKS

- **Spark Plugs** – The spark plugs are located at the top of the cylinders. As their name suggests, they provide the spark to ignite the mixture of fuel and air.
- **Timing Belt** – To keep this cycle going constantly, the timing belt is hooked up to the crankshaft. This belt essentially creates a pulley system that's used to keep the rotation going.
- **Camshaft** – The top of the timing belt is hooked up to the camshaft. This part controls the motion of the valves. By stringing the timing belt between the consistently rotating crankshaft and camshaft, the engine repeats the cycle so that your vehicle can keep running.

All of these parts are essential to making an internal combustion engine function. They create the necessary reaction to power your vehicle and contribute to the rotational motion that made this cycle revolutionary.





### *Four-Stroke Combustion Cycle*

Now that we've explored the parts that make up the engine and its cycle, let's look at the specifics of how it all comes together to create that explosive reaction.

Most automobiles run on a 4-stroke combustion cycle. This is also sometimes referred to as an Otto cycle. Besides being an appropriate sounding name, it's in honor of Nikolaus Otto, who first invented the cycle in 1867. There are four steps to the process:

1. The first motion is called the **Intake Stroke**. Here, the piston is at the top of the cylinder. The intake valve then opens to allow air in. The piston then lowers down to draw air into the cylinder.
2. Next there's the **Compression Stroke**. The valve closes, and the crankshaft drives the piston up again. This motion and the sealed intake valve force the air and fuel to compress and mix together.



3. The reaction takes place when the piston finally reaches the top of the cylinder. This is the **Combustion Stroke** or **Power Stroke**. At this moment the spark plugs do their job and create a spark, igniting the air and fuel mixture.
4. To complete the cycle, the piston then goes down again, and the outtake valve or exhaust valve opens up. This is known as the **Exhaust Stroke** because the piston will then force out all the exhaust from the reaction. This air ends up being pushed out your vehicle's tailpipe.

It's very likely that you'll find this type of engine and cycle under your hood. However, there are other types of engines and even different sizes and configurations of ones that use the four-stroke cycle.

### **Ignition System**

While this is what's going on inside your engine during your drive, what happens when you turn your key in the ignition? How does the vehicle start and the whole process begin?

As you turn the key, an electric starter motor begins to spin. This energy is then transferred to the rest of the system by a part called a starter solenoid. This electrical charge is then transferred to a distributor. This part has an ignition wire connected to each one of the cylinders.

These ignition wires carry that energy and electrical current to the spark plugs where they create the charge and reaction to get your engine up and running.



## HOW A CAR ENGINE WORKS

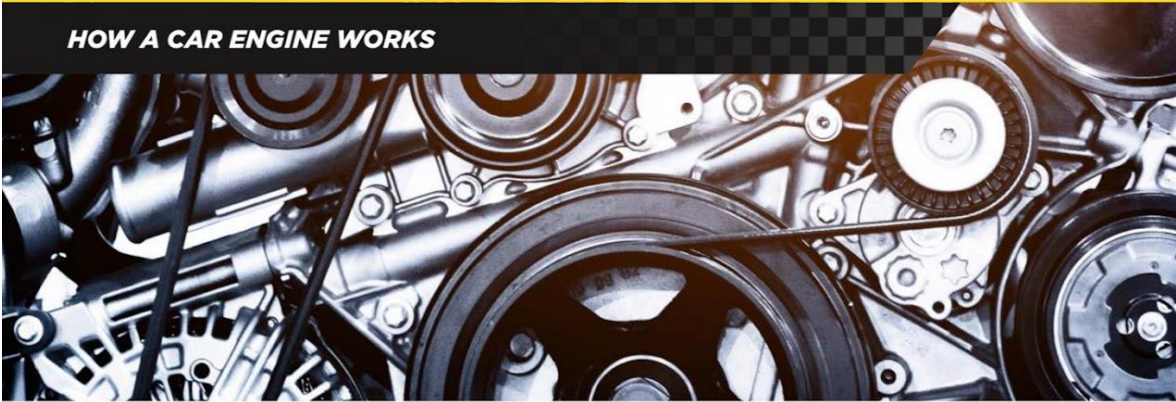

### *Types of Engines*

An engine that uses the four-stroke combustion cycle can still appear in a couple different ways. If you drive a sedan or a hatchback, you likely have an **inline engine** block. This means that all four of your cylinders are arranged standing upright and in a straight line.

Since power is generated in the cylinders, more cylinders means more power. Many muscle cars, trucks, and SUVs feature six or eight cylinders. Their engines are usually referred to as **V6** or **V8** because the cylinders are positioned at an angle that makes them form a V shape. Some V8 engines are built with a unique alternate design in their cylinders referred to as a hemispherical combustion chamber or **HEMI**<sup>®</sup>. A combustion chamber is where the fuel and air mix are ignited by the spark plugs.

In a typical engine, the combustion chamber is flat. By having a larger chamber that's shaped like half a sphere, more power can be created in each cylinder.

On the other end of the spectrum, a **2-stroke cycle engine** cuts the steps in half. It produces a combustible reaction every two strokes by removing the valves and igniting the spark plugs every time the piston reaches the top of the cylinder.

This makes 2-stroke engines very effective but, since they're smaller, they're most often used in tools like lawn mowers and chainsaws, as well as some motorcycles.

While these types of engines are different in size, shape, and output, they all still follow the same basic rotation and each of them runs on gasoline. However, a **diesel engine** uses a very different method of creating combustion.

## ***Diesel Engines***

Named after its inventor, Rudolf Diesel, it's often credited with being a driving force behind the industrial revolution. While it was created for powering heavy machinery in factories, it was later scaled down and adopted as an alternate way to power motor vehicles.

There are two big differences between a gas and diesel engine. The first is that these engines run on specialty diesel fuel instead of gasoline. You've probably seen that it has its own separate pump at the gas station.

The second difference is that a diesel engine has no spark plugs. Instead, it relies on pressure and heat from the compression stroke to create the combustion. Since there is no spark to ignite the fuel and air mixture, a diesel engine needs its pistons to compress more. This creates more heat and energy which gives this type of engine more torque and also allows it to be more fuel-efficient than its gasoline powered counterparts.

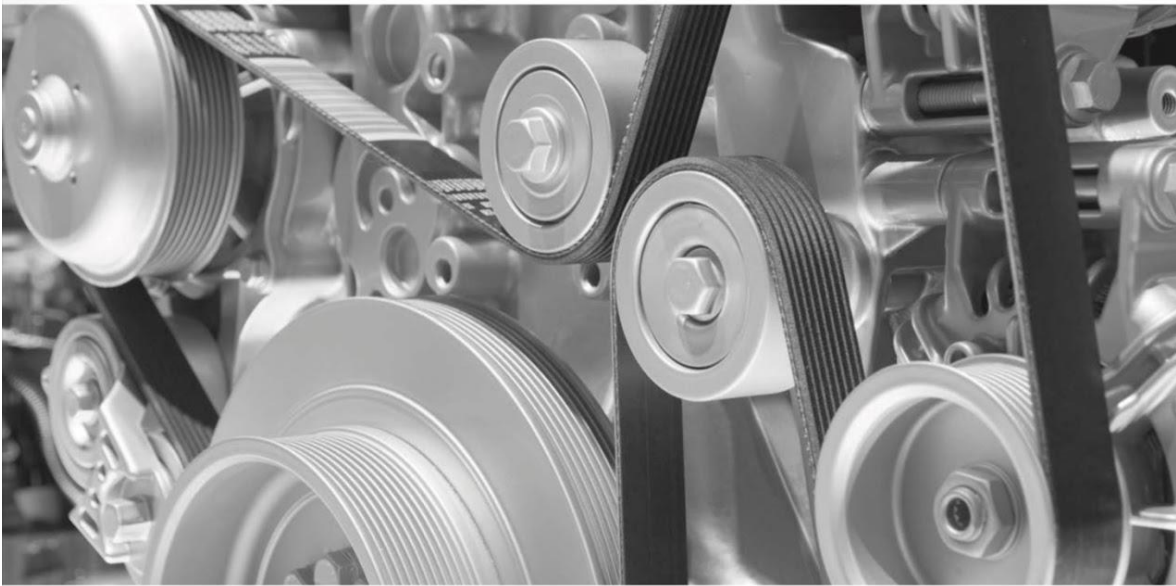

## HOW A CAR ENGINE WORKS

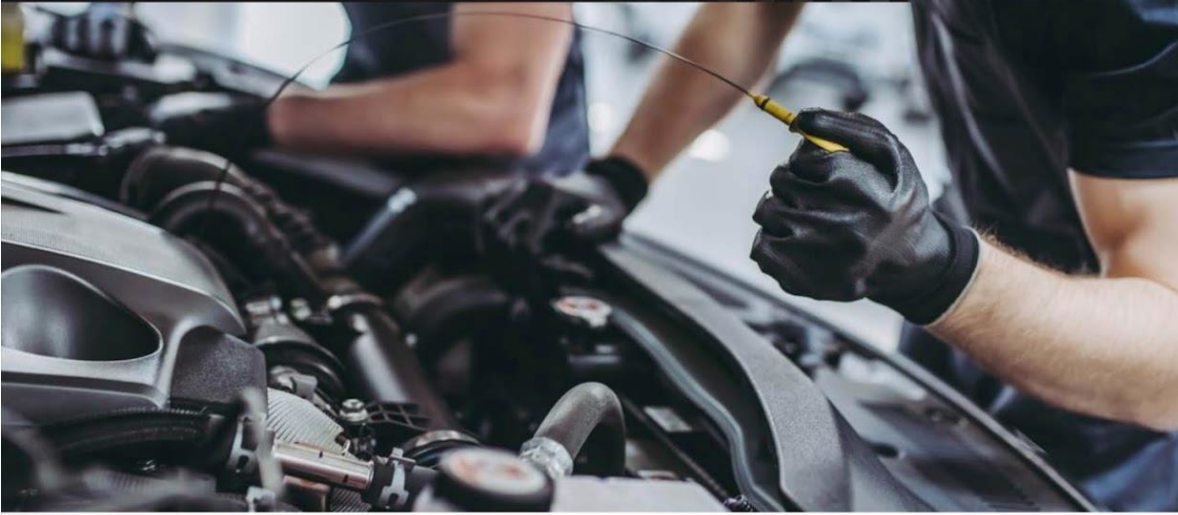

### ***Maintaining Your Engine***

Your engine is constantly at work. With all those moving parts, a lot of heat builds while you're driving. Over time that heat can create friction and cause breakdowns. That's why it's so important to stay on top of your maintenance schedule.

Fluids like coolant and engine oil are used to keep the engine temperature cool and lubricate your parts so that they can operate smoothly. Getting your air filters replaced can help keep debris out of the engine block when your pistons are drawing air into the intake valves.

With regular trips to the service center for oil changes, coolant refills, and new air filters your engine will consistently deliver by giving you peak performance. Keeping up with routine maintenance is the best way to keep your engine clean and running well.

If you have any questions or would like to learn more about your car's engine, contact your local dealership today.

# ¿CÓMO FUNCIONA **EL MOTOR** DE UN AUTOMÓVIL?

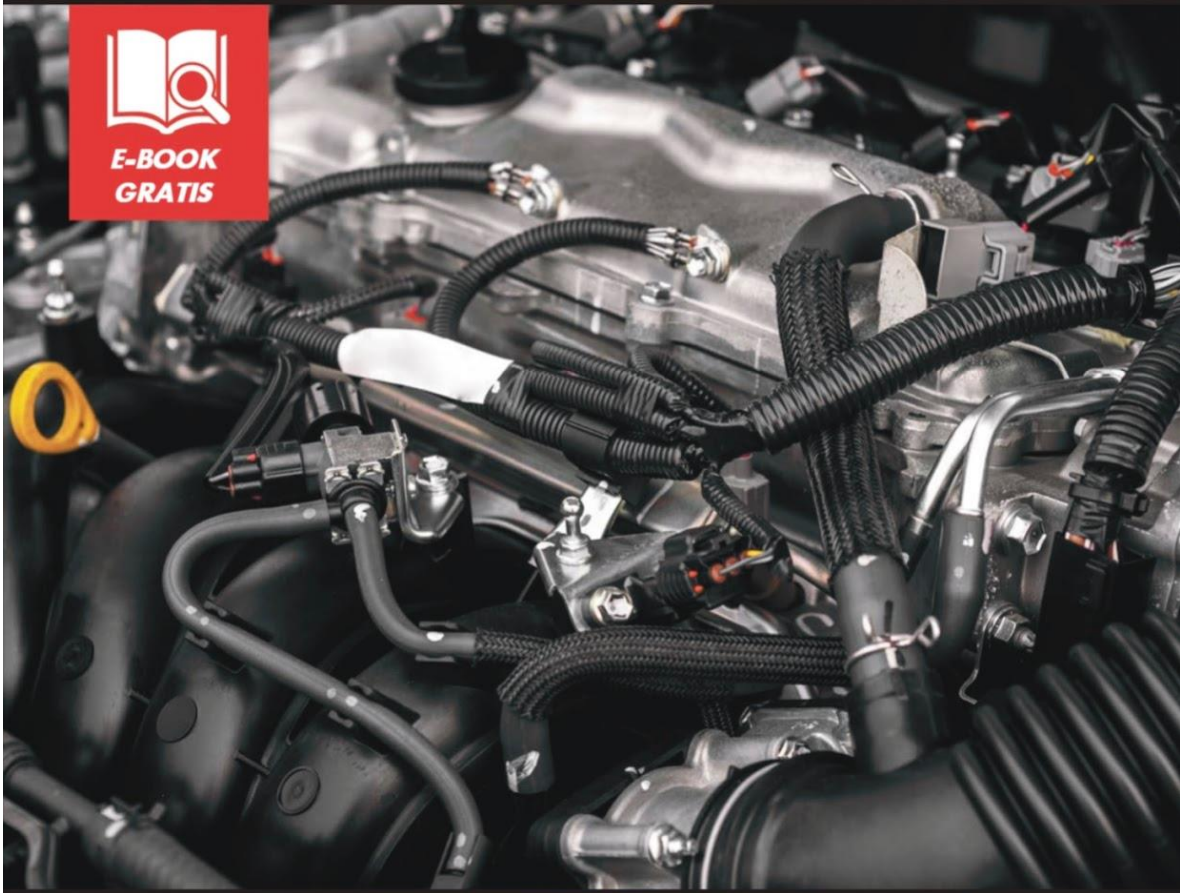

888-512-4787 | 451 North Nova Road, Daytona Beach, FL | [DaytonaToyota.com](http://DaytonaToyota.com)



## ¿CÓMO FUNCIONA EL MOTOR DE UN AUTOMÓVIL?

Cada día cuentas con tu automóvil para llegar a tu destino. Tan fácil como girar la llave, o presionar el botón de arranque, y listo ya estas en camino. Pero, ¿Sabes cómo funciona en realidad? **¿Qué es lo que permite que el motor se ponga en marcha?**

Continúa leyendo y conocerás aún más sobre lo que sucede debajo del capó mientras conduces.



### ¿CÓMO FUNCIONA EL MOTOR DE UN AUTOMÓVIL?

La mayoría de los automóviles y vehículos de motor son impulsados por lo que se conoce como motor de combustión interna, esto gracias a la combinación de combustible, aire y una chispa, el cual generan pequeñas explosiones que ponen en marcha el vehículo. Este ciclo se genera una y otra vez al alternar las piezas del motor de manera constante.

Después de casi 200 años en el que la máquina de vapor estuvo en la cima de la innovación moderna, el ingeniero francés J.J. Etienne Lenoir inventó el primer motor de combustión interna en 1859; siendo el primer motor de combustión a gasolina de funcionamiento continuo.

**Su principio básico es permitir la entrada de aire a través de una válvula de admisión, este accede a un cilindro donde se combina con combustible, por lo general, gasolina. Luego, las bujías producen la chispa que genera una pequeña explosión, creando la energía necesaria que permite funcionar al automóvil.**

Este proceso es continuo y la energía creada en el cilindro es expulsada a través del tubo de escape, el cual permite a este conjunto de sistemas el funcionamiento del ciclo de combustión.





### Partes del motor

El motor de combustión interna utiliza el movimiento para repetir el ciclo. Si bien se basa en una explosión que facilita que este proceso funcione, la idea básica detrás de su rotación es similar a una máquina de vapor o una rueda hidráulica. Algunas de las partes fundamentales son:

- **Monoblock** – Esta es la base del motor. Por lo general, está fabricado en aleación de aluminio o hierro, el cual aloja los cilindros en su interior, donde el ciclo de combustión se desarrolla. En la actualidad, la mayoría de automóviles cuentan con un motor de 4 cilindros, no obstante muchos otros poseen seis u ocho.
- **Válvulas** – Las válvulas de admisión y de escape constituyen el sistema que controla la entrada y salida de aire. Por lo general, cada cilindro posee una válvula, y cada una de ellas es esencial para la circulación del aire a través del motor hasta ser expulsado por el escape al final del ciclo.
- **Pistones** – En el interior de cada cilindro, se encuentra un pistón de metal sólido que se mueve de arriba a abajo, el cual se encarga del ciclo de combustión.
- **Cigüeñal** – El cigüeñal está unido a la base de cada pistón por un eje que controla el movimiento de arriba a abajo de los pistones.
- **Bujías** – Las bujías están situadas en la parte superior de los cilindros cuya función es generar la chispa necesaria que activa la mezcla de combustible y aire.
- **Faja de distribución** – La faja de distribución está conectada al cigüeñal que utiliza un sistema de poleas para sincronizar el movimiento de las válvulas y pistones.
- **Árbol de levas** – El árbol de levas, junto con la faja de distribución, controlan la apertura y cierre de las válvulas; por lo tanto, la sincronización de la faja de distribución, el cigüeñal, y el árbol de levas permiten que el motor continúe funcionando.

Todas las partes del motor de combustión interna son esenciales para su buen funcionamiento. Crean la reacción necesaria para el movimiento de rotación que pone en marcha al vehículo, convirtiendo al ciclo de combustión en una innovación para la época.



### ***Ciclo de combustión de cuatro tiempos***

Ahora que conocemos las partes que componen el motor y su ciclo, veamos a detalle cómo se relacionan para producir esa reacción explosiva.

La mayoría de los automóviles funcionan con un ciclo de combustión de 4 tiempos, conocido como ciclo Otto, en honor a Nikolaus Otto, quien lo inventó en 1867. Este ciclo de combustión consta de cuatro pasos:

1. La primera fase se denomina **Admisión**. En este paso, el pistón se encuentra en la parte superior del cilindro. La válvula de admisión se abre para permitir la entrada de aire, el pistón desciende e inyecta aire al cilindro
2. La segunda fase se denomina **Compresión**. La válvula se cierra y el cigüeñal sube de nuevo el pistón. Este movimiento, con la válvula de admisión sellada, provoca que el aire y el combustible se compriman y mezclen.

3. La reacción se produce cuando el pistón alcanza la parte superior del cilindro; a esto se le conoce como **Explosión o Expansión**. En este punto, las bujías generan una chispa que activa la mezcla de aire y combustible.



4. Para concluir el ciclo, el pistón vuelve a bajar, y la válvula de salida se abre. A esto se le conoce como **Escape** debido a que el pistón expulsa todos los gases producidos durante la reacción; estos terminan siendo empujados fuera del tubo de escape del vehículo.

Es muy probable que encuentres este motor de cuatro tiempos debajo de tu capó. Sin embargo, existen otros tipos de motores de diferentes tamaños y configuraciones que utilizan este mismo ciclo.

### **Sistema de encendido**

Ahora que conoces lo que sucede dentro del motor de tu vehículo cuando conduces, ¿Sabes qué sucede cuando giras la llave de encendido y cómo inicia todo este proceso?

Al girar la llave, el motor de arranque eléctrico se activa, y la energía es transferida al resto del sistema a través del relevador de arranque, luego la carga eléctrica se transfiere a un distribuidor conectado a cada uno de los cilindros a través de cables.

Estos cables de encendido llevan la corriente eléctrica a las bujías, donde se produce la carga y la reacción para poner el motor en marcha.

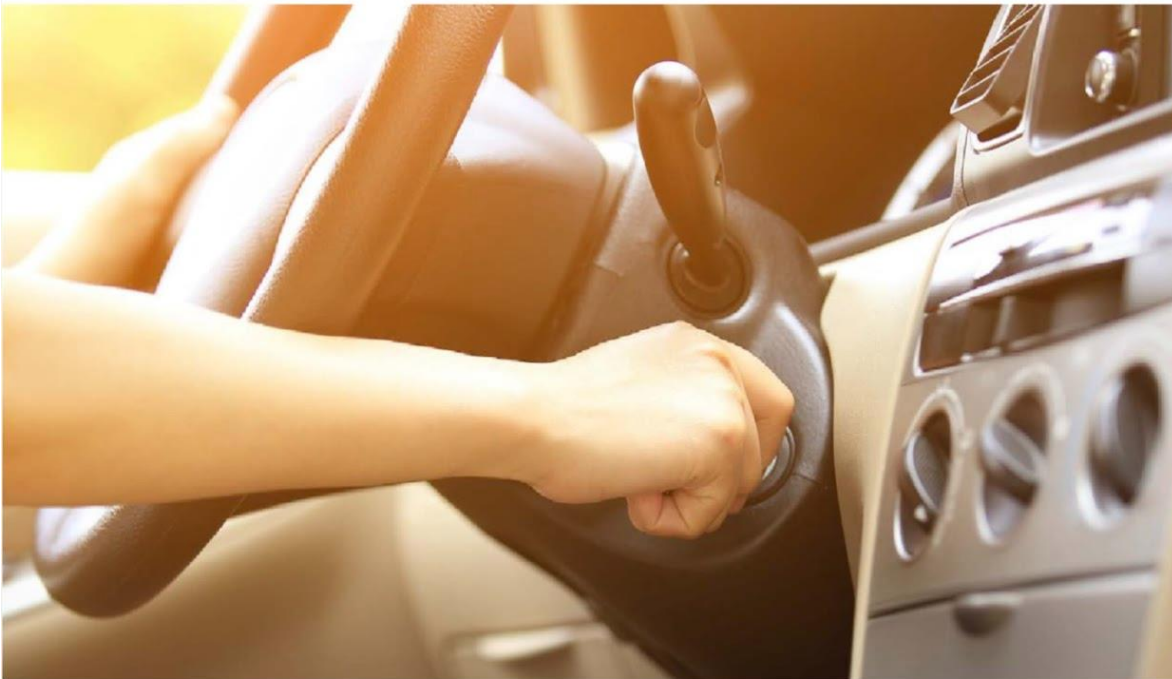

### ***Tipos de motores***

Los motores que utilizan el ciclo de cuatro tiempos pueden tener ciertas variaciones. Si conduces un sedán o un *hatchback*, es probable que tengas un **bloque de motor en serie**, es decir, que los cuatro cilindros están ubicados en posición vertical y en línea recta.

La potencia del motor depende de la cantidad de cilindros que posee, a mayor cantidad de cilindros, mayor potencia se genera. Vehículos de carrocería pesada, como camiones o 4x4, cuentan con motores de seis u ocho cilindros, conocidos como **V6** o **V8** respectivamente, debido a que sus cilindros se colocan en un ángulo que forma una V. Algunos cilindros en motores V8 poseen un diseño diferente llamado cámara de combustión hemisférica o **HEMI**®, en la cual las bujías encienden la mezcla de combustible y aire.

Por lo regular, la cámara de combustión en los motores es plana, sin embargo las cámaras de combustión en forma de semicírculo generan mayor potencia.

Por otro lado, un **motor de 2 tiempos** reduce los pasos a la mitad, ya que no posee válvulas, y produce una reacción de combustible cada dos ciclos, encendiendo las bujías cada vez que el pistón llega a la parte superior del cilindro.

Esto hace que los motores de 2 tiempos sean muy efectivos; dado que son más pequeños, se utilizan con mayor frecuencia en herramientas como cortadoras de césped y motosierras, así como en algunas motocicletas.

Si bien este tipo de motores son diferentes en tamaño, forma y potencia, todos emplean la misma rotación básica y funcionan con gasolina. Sin embargo, el **motor diésel** utiliza un método muy diferente para generar combustión.

### **Motores diésel**

Llamado así en honor a su inventor, Rudolf Diesel, se le suele atribuir ser uno de los pilares fundamentales detrás de la revolución industrial. En sus inicios, se empleó en maquinaria pesada en fábricas, más tarde se adaptó y se convirtió en una alternativa para propulsar vehículos de motor.

El motor diésel y el motor de gasolina se diferencian por el tipo de combustible que utilizan. Cada uno de ellos funciona con su propio combustible, diesel y gasolina; habrás notado que en las gasolineras cada uno posee su propio dispensador.

De igual manera, un motor diésel no posee bujías, en su lugar, depende del calor y de la compresión para generar la combustión. Dado que no posee bujías que activen la mezcla de combustible y aire, este requiere mayor compresión de los pistones. Como resultado genera más calor y energía, lo que produce una fuerza de rotación superior, ahorrando más combustible en comparación con su contraparte a gasolina.

¿CÓMO FUNCIONA EL MOTOR DE UN AUTOMÓVIL?

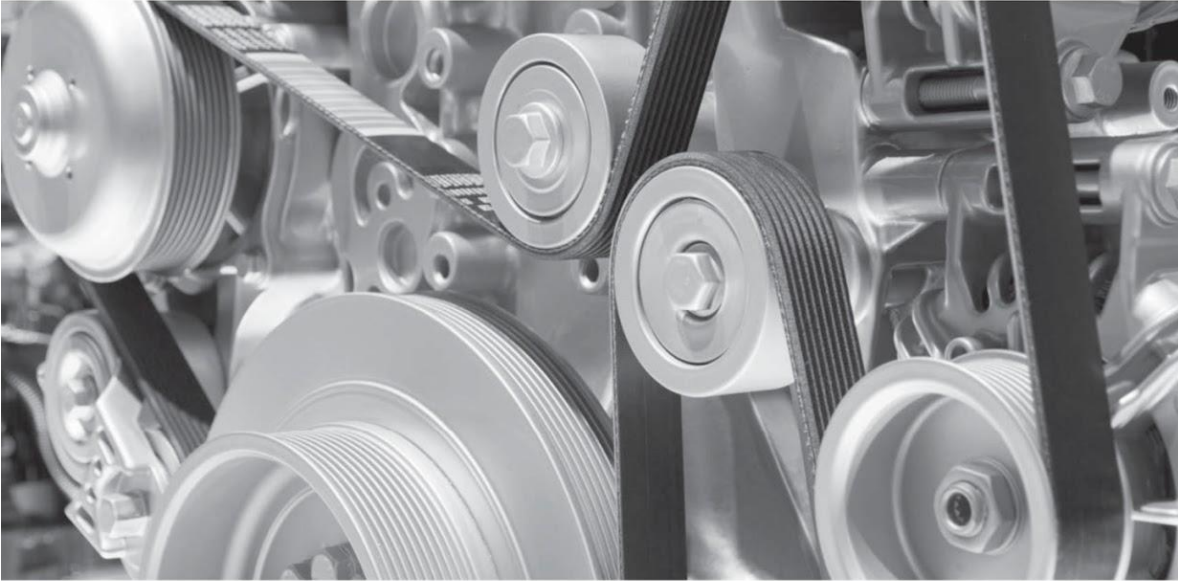



### ***Mantenimiento del motor***

Tomando en cuenta que el motor está en constante funcionamiento, es normal que acumule mucho calor mientras conduces. Con el paso del tiempo, ese calor puede crear fricción y causar averías, por esta razón es muy importante estar al corriente con su mantenimiento.

Los fluidos como el refrigerante y el aceite se utilizan para mantener la temperatura del motor estable y lubricar sus piezas para que puedan funcionar sin problemas. Los pistones permiten la entrada de aire hacia las válvulas de entrada, por ello, el reemplazo de los filtros de aire ayudan a mantener el monoblock limpio.

Las visitas frecuentes al taller por cambios de aceite, recargas de refrigerante y nuevos filtros de aire, optimiza y alarga el rendimiento del motor. El mantenimiento rutinario es la mejor manera de conservar un motor limpio y en buen estado.

Si tienes alguna duda o deseas obtener más información sobre el motor de tu automóvil, comunícate con tu mecánico local de confianza hoy mismo.

# OPERATION MANUAL

**CAR MP5 PLAYER WITH  
7 INCH HD DISPLAY PANEL  
FM RADIO RECEIVER  
BT  
MIRRORLINK**





## **Before installation**

Thank you very much for purchasing and using our products, when you receive the product, please do not take the product directly to the car for installation, because the product is in the after a long journey, it may affect the product. Please try the machine before installing.

**Test method:** Take the machine to the battery of the car and test it. This car stereo applies to a power supply voltage at 12V DC, Connect the red and yellow wires of the power cord of the machine together and connect it to the positive pole of the battery. The black wire of the power cord is connected to the negative pole of the battery. Wait for 10 seconds after connecting, press each button of the machine to see if the machine can boot normally. If it can be turned on, it means there is no problem, you can install it. If the test machine can not start normally, please again Confirm that you follow the steps of our test method in strict accordance with the operation. If the problem is still not solved, please contact our work in time.  
Thank you for your cooperation.

## **BASIC PARAMETERS**

Operating Voltage	DC12V
Maximum Current	15A
Operating Temperature	-10~+60 °C
Screen Size	7 Inch
Screen Resolution	800*480
System	Windows CE
Output Power	60W x 4
BT Function	Ver:4.0 Built-in microphone
Phone Link	Android/Iphone (Some high version phones do not support)
Support Video Format	RM/RMVB/FLV/3GP/MPEG/DIVX/DAT/VOB/AVI/MP4
Support Audio Format	MP3/WMA/WAV/FLAC/APE/OGG/
Support Picture Format	JPG
Button Light	Colorful light automatic / Monochrome light optional
Radio Frequency	FM 87.5~108MHz
Support media devices	USB 2.0/TF card
AUX Input	Front panel 3.5mm interface
Reverse Function	Support (camera option)
Remote Control	Infrared remote control
Language Selection	English/Chinese/Spain/Portugal/French/Italy/Russia/German/Turkey/Czech/Polish/Thai
Steering Wheel Controls	Support

## **UNIT INSTALLATION SIZE**



## PANEL COMPONENT DESCRIPTION

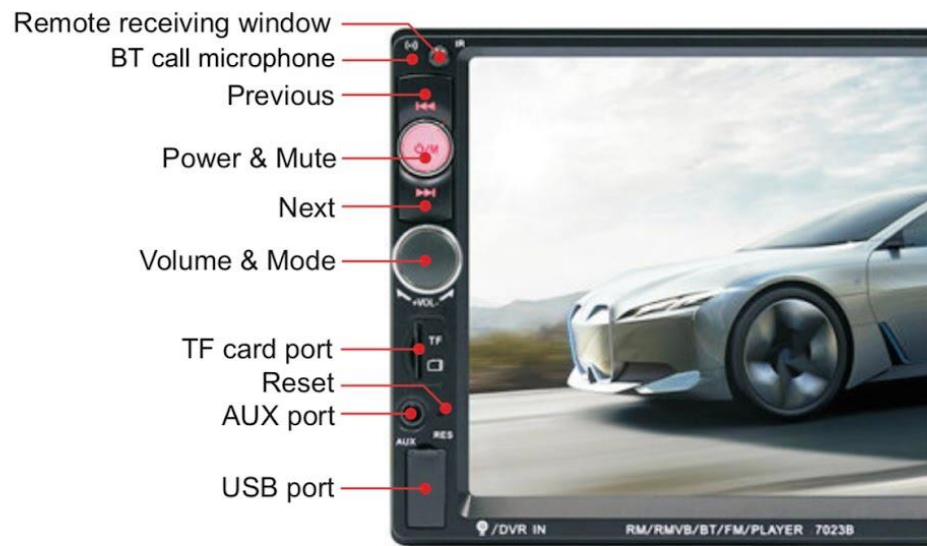

## REAR INTERFACE DESCRIPTION

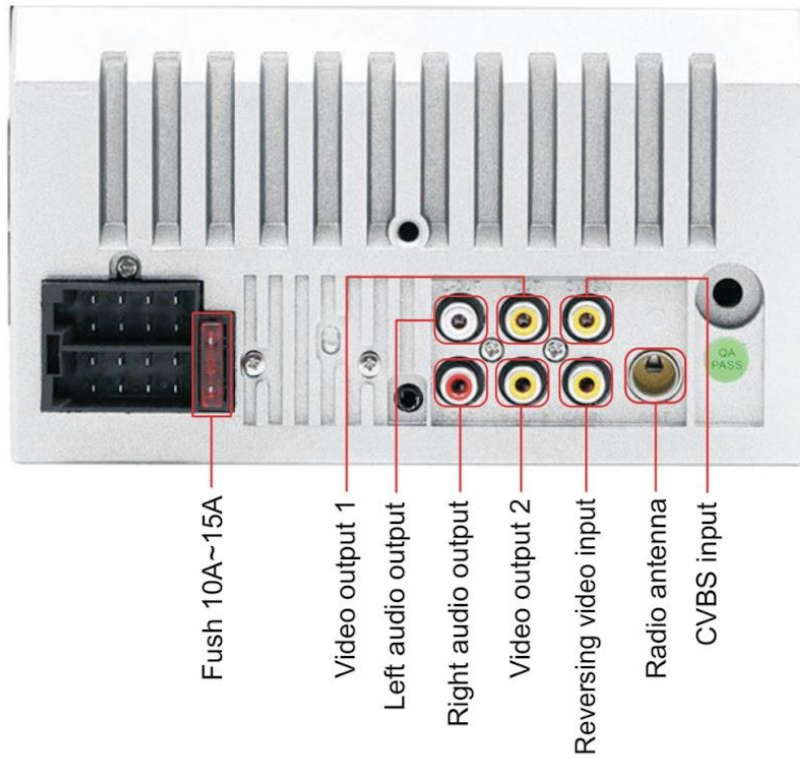

## PANEL COMPONENT DESCRIPTION

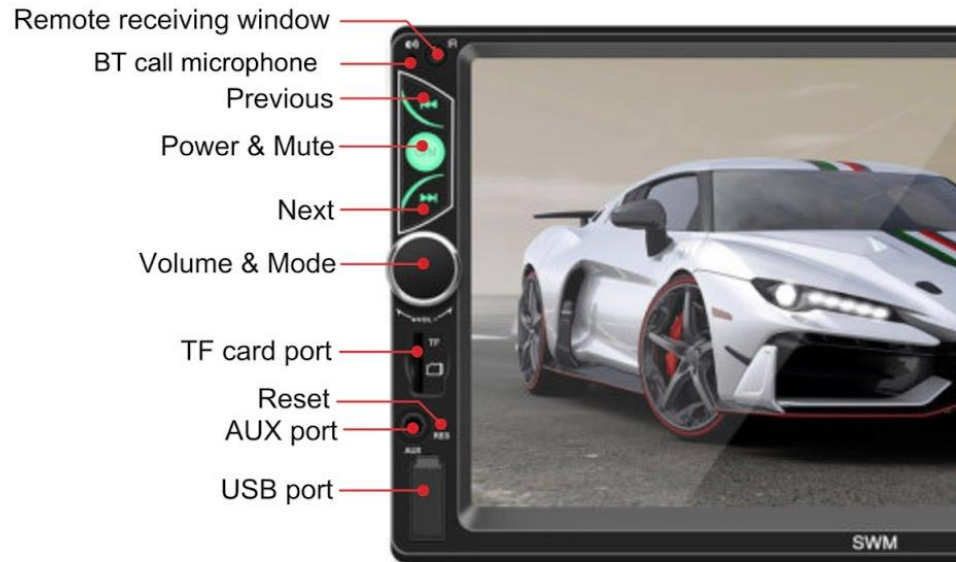

## REAR INTERFACE DESCRIPTION

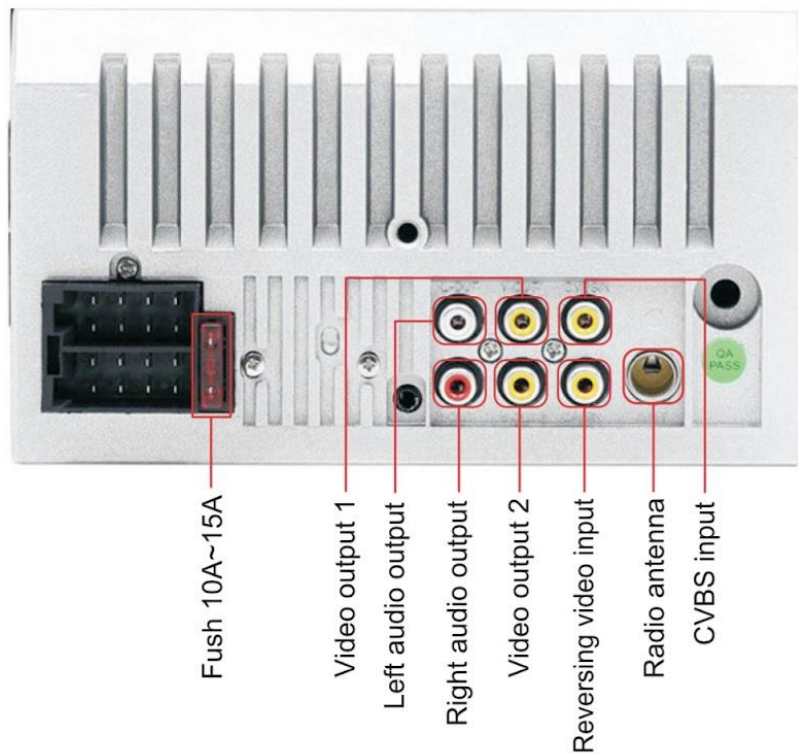

## REAR INTERFACE DESCRIPTION

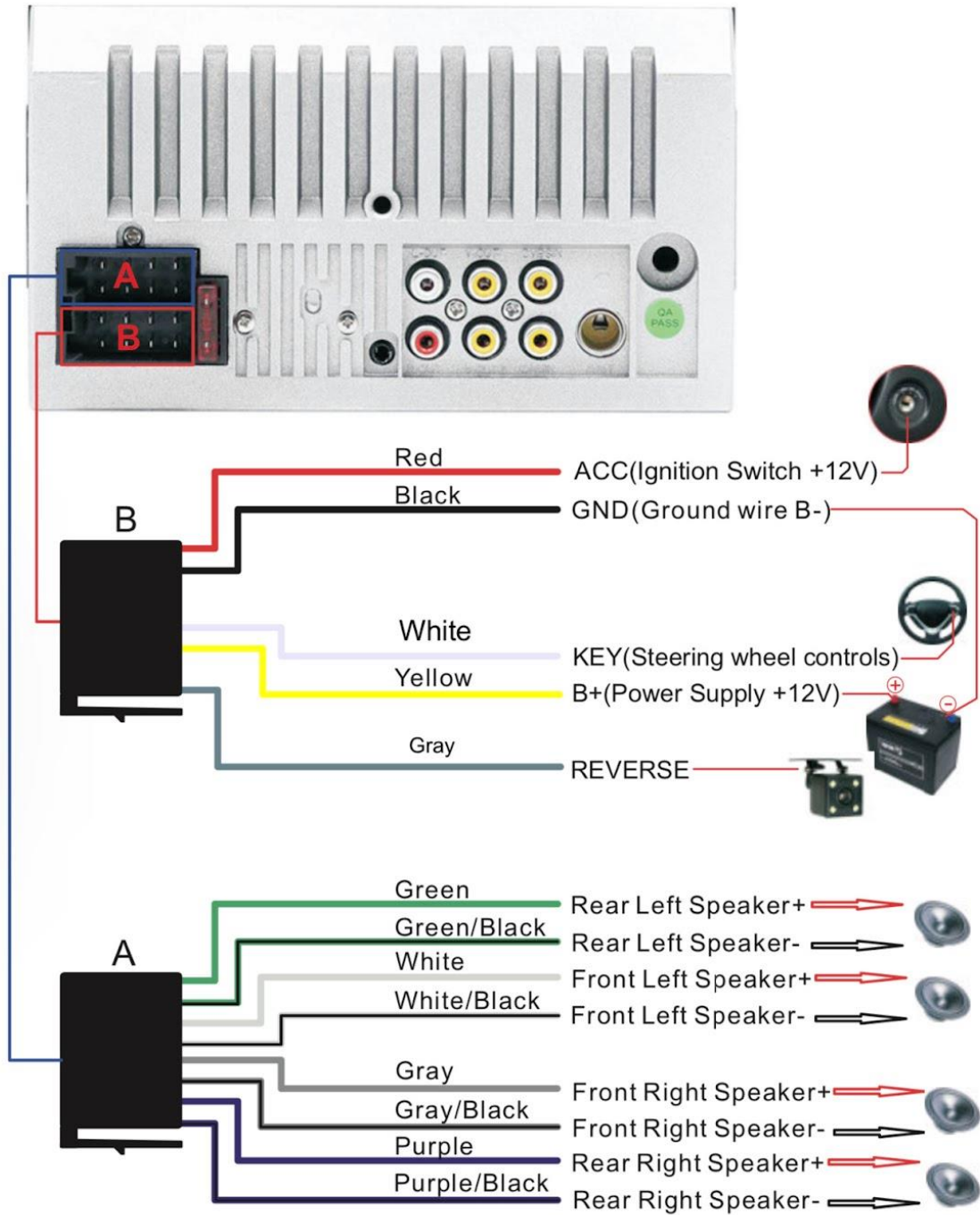

## **PHONE LINK FOR IPHONE**

\* For iOS, X series and higher versions of mobile phones do not support mobile “phone link” with this machine.

1. Connect the machine and mobile phone with the original data cable.
2. When the phone pops up a dialog box: Trust This Computer? Select Trust to enter the interconnect mode.



## **STEERING WHEEL CONTROLS**

1. Connect the positive pole of the original steering wheel to the KEY(White) line of the machine plug.
2. Connect the negative pole of the original car steering wheel button wire to the GND(Black) wire of the machine plug.
3. In the "settings" interface, find "Steer" and enter.
4. Enter the steer and press the button to learn. After the learning is successful, click the "OK" button on the page. After saving, you can use the buttons on the original steering wheel to control the machine.

**Learning method:** press and hold a button on the steering wheel of the original car without letting go, find the button icon corresponding to the function of the button on the steering wheel of the machine. Click this icon to change the color, indicating that the button has been successfully learned, according to the same. The way you can learn other buttons. After all the keys have been learned, click the "OK" button on the page to save the settings. If you need to relearn, please click the "RESET" button on the page and then re-learn.

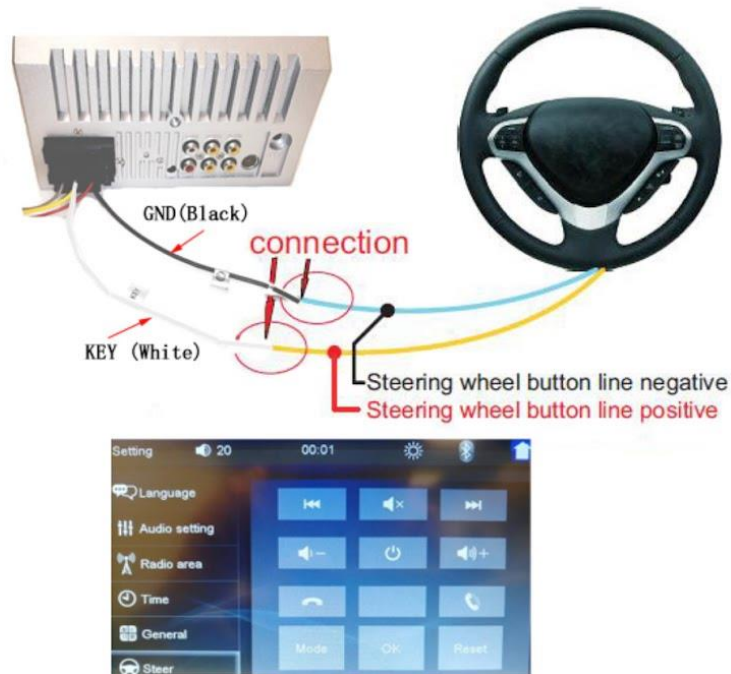

## **COMMON PROBLEMS AND SIMPLE TROUBLESHOOTING**

### **1> Unable to boot normally**

--- Reason for not booting

1. "Yellow" "Red" "Black" this 3 lines only connected 2 line of them, so it will not start, it should be that the yellow line is connected to the positive pole, red line to the key control line, black to the negative pole, less connection or wrong connection does not boot.
2. The original car line and unit wiring can not be connected to the color, the color of the original car line is not standard, if you connect like that it can not only be turned on but also may burn.
3. The original car plug can't be plugged directly into the new unit, even if it just plugs in, it can't be used, otherwise it won't be turned on or burned.
4. The 3 wires are connected right, but it does not boot. Check if the fuse on the yellow line is broken. If there is no problem with the fuse, twist the yellow and red wires together. Turn on the key and press the unit's power button to see if it can be turned on.
5. Every time you change the fuse, it burns. Please don't change it again. The reason is that when you first connect the positive and negative poles, the protection circuit of the unit is short-circuited. The unit can be repaired under the guidance of our master. No basis can only be returned to the after-sales or new unit. If these are no problem, or also don't boot, please make the final step to confirm, find a 12V battery or 12V power supply "yellow" and "red" twist together with the positive, black to the negative pole, press the button check if it can boot or no, if you can boot, it showed that the original car line is not right connect, or there is a problem with the car line. If it can't be boot, the unit is broken. Does not boot unit, check the line carefully, do not blindly suspect the unit problem.

### **2> Automatic shut-down**

--- Automatic shutdown usually has these following conditions

1. The cable error connect: If the blue cable (automatic antenna power supply) is connected to the power cable of the unit, an automatic shutdown will occur. Please follow the correct wiring method to solve the problem.
2. The voltage is unstable: please find a 12V-5A which one is the power supply and re-tested to see if it will automatically shut down or no. If it does not automatically shut down after the test, please replace the power supply. If it will automatically shut down, it is problem with the unit.

### **3> Having noise**

--- The general situation of noise is caused by two reasons

1. The original speaker power is too small. When the volume of the unit is turned up, there will be noise.  
**Solution:** When replacing the speaker or listening to the song, the volume should not be too large.
2. The speaker cable is grounded.  
**Solution:** Take the iron speaker cable. Directly connected to the speaker cable of the unit.



#### **4> Settings cannot be saved ( no memory )**

--- There is no memory function, there is only 2 points in memory

1. The yellow line and the red line are connected together (separate yellow to positive, red to key control).
2. Yellow and red are reversed (just change position).

#### **5> Car audio with BT but it can't work**

--- Check the phone to see if you can search for the unit code or no.

**Operation steps:** turn on the unit, use the phone Bluetooth search, search for CAR-MP5, then click the connection, after connecting, you can answer the phone or BT to play the song

**PIN Code:** 0000 .

#### **6> The product smoke has proved that the internal circuit has been burned and change the insurance FUSE can not solve the problem**

--- In this case, the unit needs to be repaired.

#### **7> How to adjust the sound, where is the equalizer set, the sound can not be adjusted**

--- Adjust the sound: please turn the volume to adjust.

--- Equalizer settings: In general, press the volume knob to display the equalizer SEL, and rotate the volume button to adjust each sound effect.

--- The sound cannot be adjusted: 1.Please reset the unit or unplug the power cord and plug it in. 2.The Volume knob is broken, and the knob can be replaced.

#### **8> Support no image of reversing camera**

--- Generally two situations

1. Connect the wrong line or less wiring. Camera connection method:
  - a> The first step is to find accessories (accessory: one camera + one power cord + one video cable).
  - b> The second step is to find the port of the wiring.First find the reversing control line on the power line of the unit. The control line is a pink line or brown line, connect this line to the positive pole of 12V and the screen will turn blue. Find the back of the unit the CAME video input interface, find the positive and negative of the backup light. The third step is to connect: there are two sockets on the camera, the red socket is connected to the power cable, the yellow is inserted into the video cable, the red wire of the power cable and the wire of the video cable are screwed together on the positive pole of the reverse lamp, and the black wire of the power cable is not used, connected, the other end of the video cable is connected to the

CAME video input interface on the back of the unit. The red line coming out of the video line is connected to the reversing control line of the power line.

2. The camera is broken. If the lamp that is properly wired to the camera is not lit, it will be broken and replaced with a new one.

### **10> USB flash disk can not be played, the card with the map can not be recognized, the card slot does not enter the card, the map card folder has no content?**

--- USB flash disk can not play:

Format the USB flash disk, and the file system is selected as: FAT32, re-download on or two songs and try again. If it still doesn't work, please replace the USB flash drive.

--- The map card cannot be recognized(Only for GPS models):

Insert the card into the computer to format, re-download the map or change the memory card to download the map software.

--- The card slot does not enter the card:

Check whether the memory card is inserted, the plug is broken.

--- There is no content in the map card folder(Only for GPS models):

Insert the card into the computer to view it. If there is no content, you need to download it again.

### **11> FM does not receive the program**

--- Can not receive the station check the 2 points

1. The antenna plug is not fully inserted, the antenna is disconnect or the line is disconnect.
2. Search channel, hold AMS does not let go for 2 seconds The unit will automatically search or press the up and down button to perform a channel search. Can't solve the above 2 points, Please unplug the antenna plug and find a screwdriver or a metal strip to insert it instead of the antenna.

### **12> Just installed no sound**

--- Dear customers, the unit has been tested before shipment. If there is no sound, it is usually a wiring error or the original car speaker wire is short-circuited with iron. Please do not doubt the unit. According to the steps to check it.

1. Check if the speaker cable is short-circuited and connected. Please reconnect if you have any short circuit.
2. Check how many speaker cables according to the original speaker cable if there are only 2 speaker cables to prove that the original car line does not match our unit, you need to re-route the original car line. One speaker must lead to 2 speaker wires. 2 speakers must be have 4 speaker cables to available.

### **13> After a while there is no sound**

--- Disconnect all the speaker cable from the unit (do not remove all of them), and then find an external speaker to receive the gray and purple of the tail line of the unit. Green any group, and then try to see if there is any sound. If there is a sound, it is proved that the car's speaker line is short-circuited with iron or the speaker is damaged. If there is no sound, the unit is broken.

# MANUAL DE INSTRUCCIONES

**REPRODUCTOR MP5 PARA AUTOMÓVIL  
CON PANTALLA HD DE 7 PULGADAS  
RECEPTOR DE RADIO FM  
BLUETOOTH  
MIRRORLINK**



## **Antes de la instalación**

Gracias por preferir nuestros productos. Una vez lo reciba, por favor, pruebe el dispositivo antes de su instalación, puesto que durante el embalaje, pudo estropearse. No lo instale de inmediato.

**Método de prueba:** Este reproductor mp5 funciona con una fuente de alimentación de 12V DC; utilice la batería de su automóvil para probar este dispositivo. Una los cables rojo y amarillo de la línea de alimentación del reproductor, y conéctelos al polo positivo de la batería, luego conecte el cable negro de la línea de alimentación al polo negativo. Espere 10 segundos, luego presione los botones del estéreo para verificar que el dispositivo funciona con normalidad; de ser así, puede instalarlo sin problemas. Si el dispositivo presenta dificultades, por favor, asegúrese de haber seguido al pie de la letra los pasos de nuestro método de prueba. Si el problema persiste, contáctenos a la brevedad. Gracias por su colaboración.

## PARÁMETROS FUNDAMENTALES

Voltaje de entrada	CC12V
Corriente máxima	15A
Temperatura de funcionamiento	-10 ~ +60 °C
Tamaño de pantalla	17.7 cm
Resolución de	800 x 480 píxeles
Sistema	Windows CE
Potencia de salida	60W x 4
Función Bluetooth	Versión 4.0 - Micrófono incorporado
Compatibilidad	Android/Iphone (Algunos teléfonos de gama alta no son compatibles)
Formato de vídeo	RM/RMVB/FLV/3GP/MPEG/DIVX/DAT/VOB/AVI/MP4
Formato de audio	MP3/WMA/WAV/FLAC/APE/OGG/
Formato de imagen	JPG
Retroiluminación	Luz colorida preestablecida / luz monocromática opcional
Radiofrecuencia	FM 87,5 ~ 108 MHz
Compatibilidad de dispositivos	USB 2.0/tarjeta TF
Entrada Aux	Interfaz del panel frontal de 3,5 mm
Cámara de retroceso	Compatible (Cámara no incluida)
Control remoto	Control remoto por infrarrojo
Selección de idioma	Inglés/Chino/Español/Portugués/Francés/Italiano/Ruso/Alemán/ Turco/Checo/Polaco/Tailandés
Mandos al volante	Compatible



## DIMENSIONES DEL DISPOSITIVO



## DESCRIPCIÓN DE LA PARTE POSTERIOR DEL DISPOSITIVO

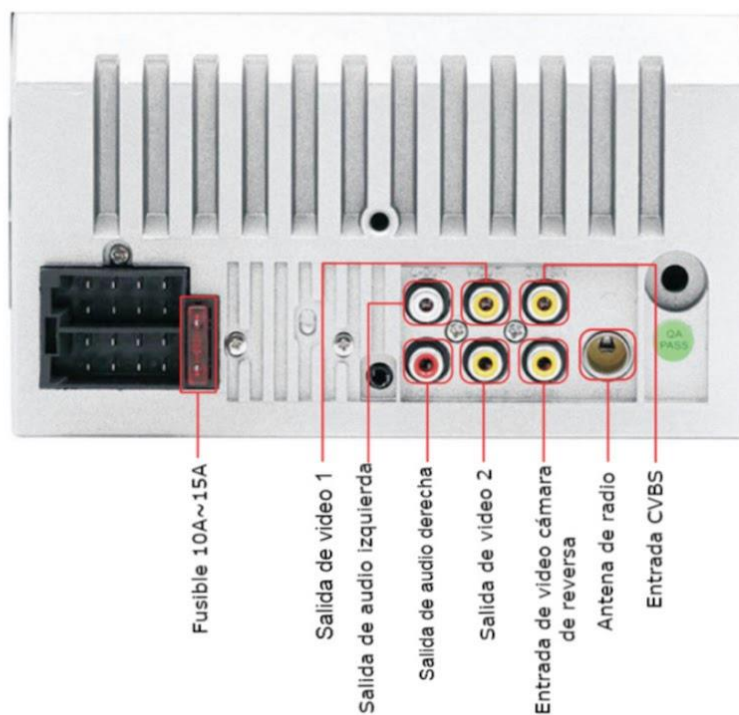

## **DESCRIPCIÓN DEL PANEL DE CONTROL**



## **DESCRIPCIÓN DE LA PARTE POSTERIOR DEL DISPOSITIVO**

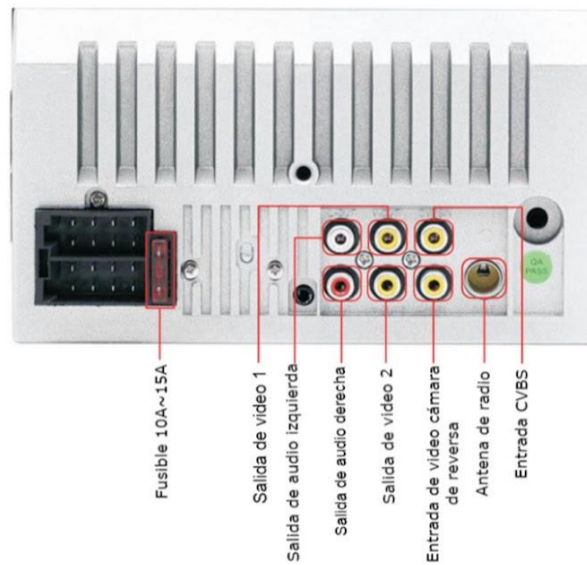

## DESCRIPCIÓN DE LA PARTE POSTERIOR DEL DISPOSITIVO

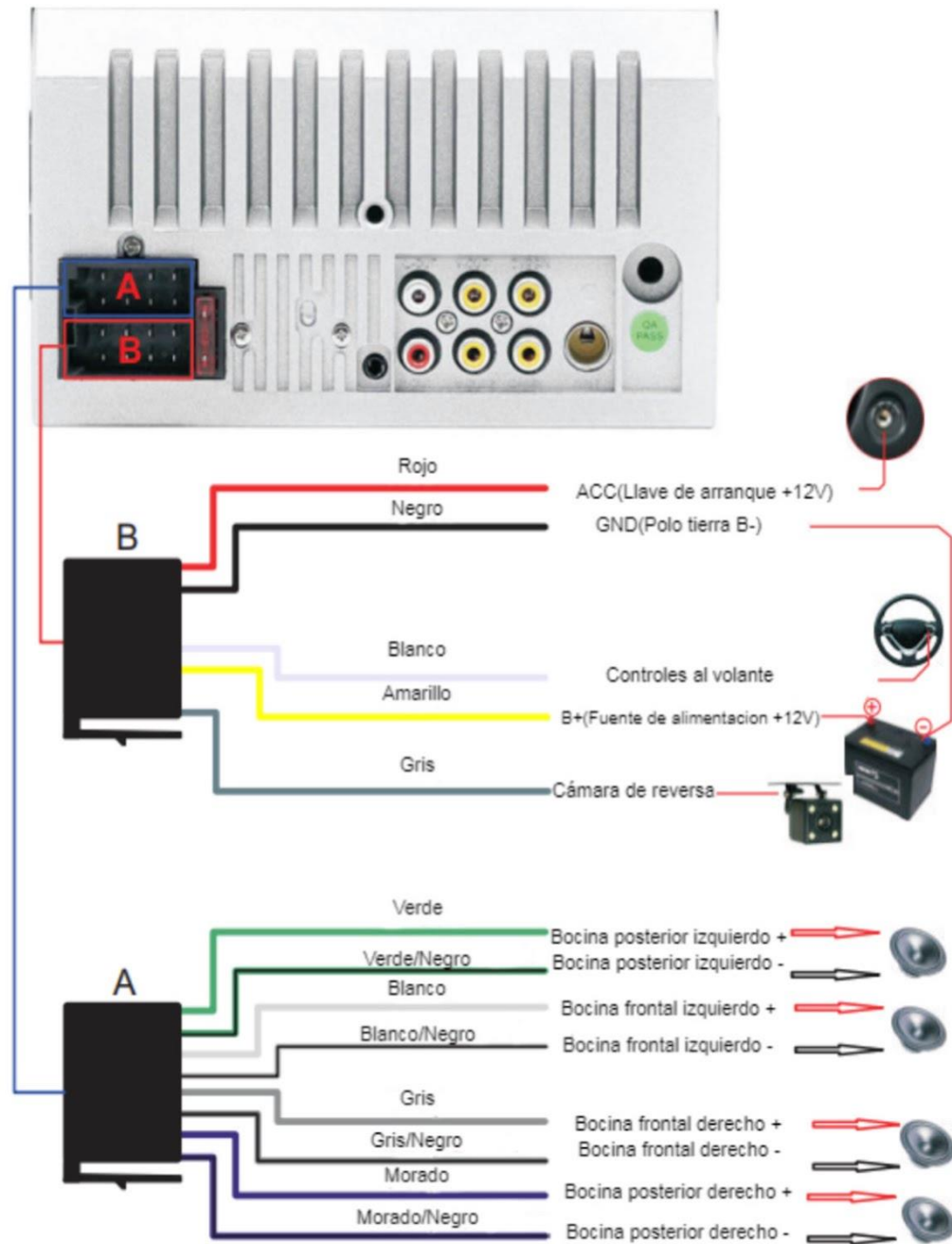



## **VINCULACIÓN CON DISPOSITIVOS IPHONE**

\* *Este dispositivo no es compatible con teléfonos serie X y modelos superiores.*

1. Conecte el dispositivo y el teléfono móvil con el cable de datos original.
2. Cuando el cuadro de diálogo aparezca en su teléfono móvil: "¿Confiar en este equipo?" Seleccione "Confiar" para permitir el modo de interconexión.



## **MANDOS DEL VOLANTE**

1. Conecte el polo positivo del volante al cable blanco del enchufe del dispositivo.
2. Conecte el polo negativo del volante al cable negro GND del enchufe del dispositivo.
3. En el menú de "configuración", seleccione la opción "volante".
4. Luego, presione el botón "configurar". Una vez completada la configuración, haga clic en el botón "Aceptar". Ahora, puedes utilizar los botones del volante para controlar el dispositivo.

**Configuración de mandos:** mantenga presionado cualquier botón del volante de su automóvil; sin dejar de presionar, busque en la pantalla del reproductor el icono que corresponda a la función del botón presionado; una vez el icono cambie de color, el botón se ha configurado con éxito. Para configurar los demás botones, repita los pasos anteriores, y haga clic en "Aceptar" para guardar sus preferencias. Si necesita configurar de nuevo los botones, haga clic en "RESTABLECER" para reconfigurarlos.



## **PROBLEMAS COMUNES Y SOLUCIONES SENCILLAS**

### **1> Dificultades al encender**

--- Posibles motivos:

1. Verifique que los tres cables, amarillo, rojo y negro estén conectados de manera adecuada. Caso contrario, no permitirá un correcto funcionamiento. El cable amarillo debe estar conectado al polo positivo, el cable rojo a la línea de control de la llave de arranque, y el cable negro al polo negativo. Si se conectan de forma errónea, no encenderá.
2. El cableado del automóvil y del reproductor no deben ser conectados de forma convencional, debido a que el cableado del automóvil no coincide con los colores estandarizados. Si se conecta de la forma tradicional, el dispositivo podría no encender, o estropearse.
3. El conector del automóvil no debe ser enchufado de manera directa al dispositivo, incluso si encaja a la perfección. Esto provocará que el dispositivo no encienda o se estropee.
4. Si los 3 cables están conectados de manera correcta, pero el dispositivo no enciende, compruebe si el fusible del cable amarillo está dañado. Si no es el caso, una los cables amarillo y rojo. Introduzca la llave de arranque, y pulse el botón de encendido del dispositivo para comprobar si funciona.
5. Si cada vez que cambia el fusible, se quema, por favor, evite cambiarlo de nuevo. Esto se debe al sistema de protección del reproductor mp5 que provoca un cortocircuito al conectar por primera vez los polos positivo y negativo; no es posible devolver el dispositivo de manera parcial o total, una vez adquirido; sin embargo el equipo puede ser reparado por nuestro equipo técnico. Si este no es el problema, y el dispositivo sigue sin funcionar, utilice una batería o una fuente de alimentación de 12V, entrelace los cables amarillo y rojo para conectarlos al polo positivo, asimismo el cable negro al polo negativo. Ahora presione el botón para comprobar si el reproductor enciende; si este es el caso, significa que el cable del automóvil no está conectado de manera correcta, caso contrario, el dispositivo está averiado. Es necesario revisar el cableado de manera minuciosa, y no asumir que el dispositivo no funciona.

### **2> Apagado repentino**

--- El apagado repentino puede darse por la siguientes razones:

1. Error de conexión de cable: El dispositivo se apagará de forma automática si el cable azul (fuente de alimentación automática de la antena) está conectado al cable de alimentación del dispositivo. Siga el método de cableado correcto para resolver el problema.
2. El voltaje es inestable: con una fuente de alimentación de 12V-5A compruebe si el dispositivo se apaga de manera súbita. Si se mantiene encendido después de la prueba, reemplace la fuente de alimentación. Si el problema persiste, significa que el dispositivo está defectuoso.

### **3> Problemas de audio**

--- Existen dos razones principales:

1. Bocinas de baja capacidad. Cuando el volumen del dispositivo sube, se produce distorsión.

**Solución:** Reemplace la bocina o modere el volumen cuando se reproduzca contenido multimedia.

2. El cable de la bocina está conectado a polo tierra.

**Solución:** Tome el cable de la bocina y conéctelo directo al cable de la bocina del reproductor.

### **4> Imposible guardar ajustes (memoria no reconocida)**

--- Si sus preferencias no se guardan, siga los siguientes pasos

1. Si los cables amarillo y rojo están entrelazados, separe las líneas y asegúrese que el cable amarillo está conectada al polo positivo, y el cable rojo está conectado a línea de control de la llave de arranque.
2. Si la posición de los cables amarillo y rojo está invertida, cámbielos de posición.

### **5> Problemas de audio y conexión bluetooth.**

--- Busque el nombre del dispositivo, CAR-MP5, en su teléfono móvil.

**Pasos a seguir:** encienda su reproductor mp5, busque el nombre del dispositivo CAR-MP5, seleccione "emparejar". Una vez finalizada la conexión, podrá responder llamadas y reproducir contenido multimedia desde su teléfono.

Código PIN: 0000.

### **6> La aseguradora FUSE no cubre daños por mala manipulación ni sobrecargas eléctricas en el circuito interno del dispositivo.**

--- En este caso, el dispositivo necesita reparación.

### **7> No se puede ajustar el audio desde el ecualizador.**

--- Ajustes de audio: gire el botón de control de volumen para ajustar.

--- Ajustes del ecualizador: pulse el botón de volumen para visualizar el ecualizador SEL, y gire el botón de control de volumen para ajustar cada efecto de audio.

--- No se puede ajustar el audio: 1. Por favor, reinicie el dispositivo o desconecte el cable de alimentación, y conéctelo de nuevo. 2. Si el botón de volumen está defectuoso, puede ser reemplazado.

## **8> Cámara de reversa no muestra señal de video**

--- Existen dos escenarios

1. Conexiones inadecuadas de la cámara de reversa. Método de conexión de cámara:

a> El primer paso es tener los siguientes accesorios a la mano: una cámara de reversa, una línea de alimentación, y un conector de vídeo.

b> El segundo paso es identificar cableado y entradas: busque la línea de reversa (por lo general, es el cable de color rosa o marrón), en el arnés de cableado estéreo, seguido, conecte esta línea al polo positivo de 12V; la pantalla del reproductor deberá encender en color azul. Luego encuentre en la parte trasera del reproductor, la entrada de vídeo de cámara (CAME), a su vez, identifique el polo positivo y negativo de la luz de reversa de su automóvil.

c> El tercer paso es conectar los cables: la cámara de reversa posee dos cables de video hembra; el cable rojo se conecta a la línea de alimentación que viene de la luz de reversa de su automóvil; el cable amarillo se inserta en el conector de vídeo. El cable rojo de la línea de alimentación, y el cable rojo del conector de vídeo, se atornillan juntos en el polo positivo de la luz de reversa, mientras que el cable negro de la línea de alimentación a polo negativo. El otro extremo del conector de vídeo se conecta a la entrada de video de cámara (CAME), en la parte trasera del reproductor, y el cable rojo de este extremo del conector de vídeo se une con la línea de reversa, cable de color rosa o marrón, del arnés de cableado estéreo.

2. La cámara se encuentra dañada. Si la cámara está conectada de manera correcta a la luz de reversa de su automóvil y esta no enciende, es probable que la cámara no funcione y deba ser reemplazada.

## **9> ¿No se reconoce la memoria USB? ¿La tarjeta de memoria no encaja en la ranura SD? ¿El dispositivo no reconoce el mapa de su tarjeta o la carpeta está vacía?**

--- No se reconoce la memoria USB:

Formatee la memoria USB, y seleccione el formato FAT32. Vuelva a descargar una o dos canciones e inténtelo de nuevo. Si el problema persiste, reemplace la unidad de memoria USB.

--- No es posible reconocer la tarjeta SD de Mapa (para modelos con GPS):

Inserte la tarjeta SD en el ordenador para formatear, y vuelva a descargar el mapa; o reemplace la tarjeta SD y descargue el sistema de navegación en la nueva tarjeta de memoria.

--- La tarjeta de memoria no encaja en la ranura SD:

Compruebe si la tarjeta de memoria está insertada de manera correcta, o si los conectores están dañados.

---La carpeta de navegación de la tarjeta SD está vacía (para modelos con GPS): Inserte la tarjeta en el ordenador para verificar. Si no hay contenido disponible, descarga de nuevo el sistema de navegación en la tarjeta.

## **10> Problemas al sintonizar emisoras de radio**

--- Si existen dificultades al sintonizar emisoras de radio, intente con las siguientes pasos:

1. Compruebe si la antena y el cableado se encuentran conectados de manera correcta.
2. Sintonice una emisora, y mantenga pulsado el botón AMS (memorización automática de emisoras, por sus siglas en inglés) durante 2 segundos. El reproductor buscará de forma automática las emisoras de radio, o pulse el botón arriba y abajo para realizar una búsqueda manual de emisoras. Si el problema aún persiste, desconecte la antena y utilice un destornillador o un alambre metálico para utilizarlo en lugar de la antena.

## **11> Problemas de audio**

--- Estimado cliente, el funcionamiento del reproductor mp5 ha sido verificado antes de ser enviado. Si al conectar el dispositivo no reproduce audio, es posible que exista una mala conexión o el cable de la bocina del automóvil este en cortocircuito. Por favor, no asuma que el dispositivo no funciona, y siga los siguientes pasos para verificar su funcionamiento:

1. Compruebe que el cableado de las bocinas esté conectado de manera correcta, o que no se haya producido un corto circuito. De ser así, por favor, vuelva a conectar los cables.
2. Verifique el número de líneas de entradas de audio de las bocinas de su automóvil. Nuestro reproductor mp5 funciona con dos salidas de audio por cada bocina. Si la cantidad de entradas y salidas de audio no coinciden, reacomode las líneas de entrada de audio de sus bocinas.

## **12> Si el problema persiste, continúe con el siguiente paso**

--- Desconecte las salidas de audio, gris y morada, de las bocinas de su automóvil que se encuentran en el arnés de cableado estéreo; luego conecte las salidas de audio a una bocina externa, y reproduzca cualquier contenido multimedia. Mantenga conectado las salidas de audio de color verde. Si la bocina externa reproduce el audio del contenido multimedia, la bocina de su automóvil está defectuosa. Caso contrario, el reproductor mp5 está dañado.

## Birth certificates

### Original Document



#### El Infrascrito Jefe del Registro del Estado Familiar

CERTIFICA: que a página DOSCIENTOS SESENTA Y OCHO del tomo UNO del Libro de Partidas de Modificaciones Número CINCO que esta Oficina llevó en el año de dos mil cinco, se encuentra asentada la que literalmente dice: Partida Número doscientos sesenta y ocho -, [REDACTED] hembra, nació a las once horas del día dieciocho de junio de mil novecientos noventa y cinco, en el Centro de Salud de esta ciudad, siendo hija de [REDACTED], documento único de identidad número [REDACTED], [REDACTED], Profesor, originario de Sensuntepeque, del domicilio de el barrio San Antonio de esta ciudad de nacionalidad Salvadoreña y de [REDACTED], documento único de identidad número [REDACTED], [REDACTED], de oficios domésticos originaria de Sensuntepeque, del domicilio de el barrio San Antonio, ya mencionado de nacionalidad Salvadoreña El presente asiento modifica la partida número novecientos setenta y siete, asentada a folio doscientos noventa y dos del año mil novecientos noventa y cinco en virtud de lo que ordena la Ley del Nombre de la Persona Natural.//// Alcaldía Municipal de Sensuntepeque primero de diciembre de dos mil cinco .-.- Erlinda M. de G. Registrador de Familia.- RUBRICADAS.- Es conforme con su original con el cual se confrontó y para los efectos de Ley se expide la presente en la Oficina del Registro del Estado Familiar Sensuntepeque el día veinte de diciembre de dos mil dieciocho  
/////

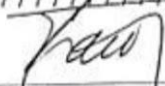
  
Lic. Carlos Antonio Montalvo  
Jefe del Registro del Estado Familiar



# Translated Document



## The Undersigned Head of the Family Status Registry

CERTIFIES: that on page TWO HUNDRED SIXTY-EIGHT of volume ONE of the book of Modified Certificates Number FIVE that this office took on the year of two thousand and five, there is the Birth Certificate that literally reads: Certificate Number two hundred sixty-eight. [REDACTED], female, was born at eleven AM on June eighteenth, nineteen ninety-five, in the Health Care Center of this city, being the daughter of [REDACTED], Unique Identity Document Number [REDACTED], Teacher, was born in Sensuntepeque, of the domicile of *Barrio San Antonio* of this city, Salvadoran, and of [REDACTED], Unique Identity Document Number [REDACTED], housekeeper, was born in Sensuntepeque, of the domicile of *Barrio San Antonio*, mentioned above, Salvadoran. This entry amends the birth certificate number nine hundred and seventy-seven, recorded on page two hundred and ninety-two of the year nineteen ninety-five by virtue of the Law of the Natural Person Name.//// Municipality of Sensuntepeque on day first of December of the year two thousand and five.- Erlinda M. de G. Family Registrar.- INITIALLED.- It is in accordance with its original which was confronted and for the purposes of the Law this is issued at the Office of the Family Status Registry of Sensuntepeque on the twentieth day of December of year two thousand and eighteen.

////////////////////////////////////

*Signature*

Carlos Antonio Montalvo  
Head of the Family Status Registry

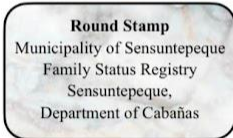



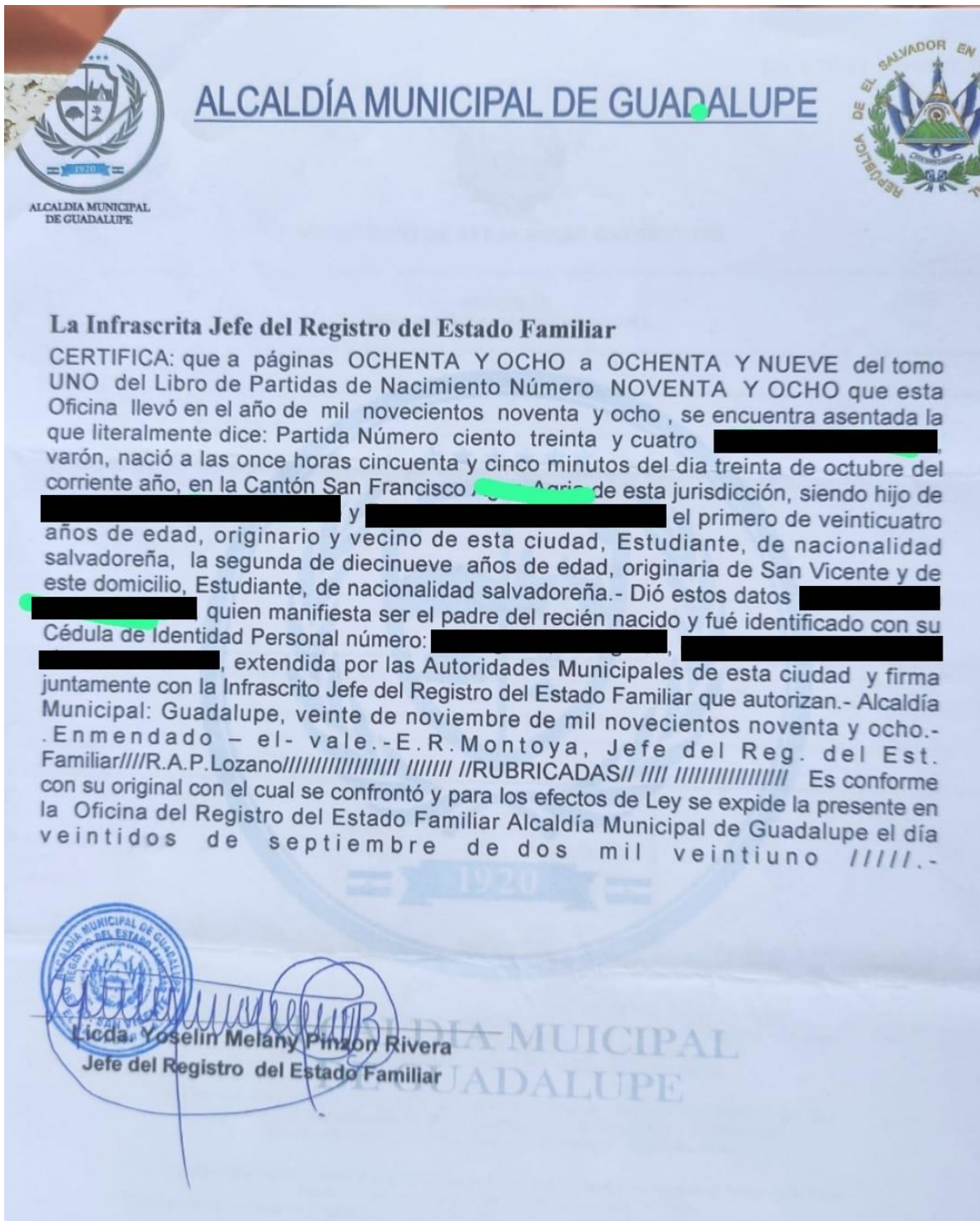

Translated Document



MUNICIPALITY OF GUADALUPE



**The Undersigned Head of the Family Status Registry**

CERTIFIES THAT : on pages EIGHTY-EIGHT and EIGHTY-NINE of volume ONE of the Book of Birth Certificates Number NINETY-EIGHT that this Office took in the year of nineteen ninety-eight, there is the Birth Certificate that literally reads: Birth Certificate number one hundred thirty-four (*Name of the newborn*), male, was born at eleven and fifty-five AM on October the thirtieth of this current year, at *Cantón San Francisco* of this municipality. His parents are [REDACTED] aged of twenty-four years old, originally from this same city, Salvadoran student, and [REDACTED] aged of nineteen years old, originally from San Vicente, with domicile in this same city, Salvadoran student.- This information was provided by [REDACTED], who attests to be the father of the newborn and exhibited his Personal Identity Card Number: [REDACTED], [REDACTED] issued and authorized by the Municipal Authorities of this city and signed together with the undersigned Head of the Family Status Registry.- Municipality of Guadalupe, November the twentieth day of nineteen ninety-eight. Amended —the- valid.-E.R. Montoya, Head of Family Status Registry //// R.A.P.Lozano/////SIGNED/// //// // It is in accordance with its original which was confronted and for the purposes of the Law, this is issued in the Office of the Family Status Registry of Guadalupe on the twenty-second day of September of two thousand and twenty-one ////.-

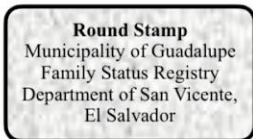

*Signature*

Yoselin Melany Pinzon Rivera  
**Head of the Family Status Registry**

# Original Document



## ALCALDIA MUNICIPAL DE SONSONATE REGISTRO DEL ESTADO FAMILIAR

Tel. 2469-3108, 2469-3100. Fax 2469-3109



El infrascrito Jefe del Registro del Estado Familiar de la Alcaldía Municipal de Sonsonate, CERTIFICA: Que a folios ciento setenta y seis del tomo quinto del libro de Nacimientos que esta institución llevó del año mil novecientos ochenta y nueve, se encuentra asentada la que literalmente dice:

Partida número mil treinta y uno. [REDACTED], sexo femenino, nació a las nueve horas del día catorce de julio del año mil novecientos ochenta y nueve, en Sonsonate; Siendo Hija de [REDACTED] de treinta y ún años de edad, Secretaria, originaria de Santa Ana y vecina de esta ciudad, de nacionalidad Salvadoreña. Dio estos datos [REDACTED] [REDACTED], de cuarenta y un años de edad, Licenciado en Administración de Empresas, originario de Santa Ana y vecino de esta ciudad y de nacionalidad salvadoreña, quién manifiesta ser Padre de la recién nacida y en tal concepto firma. El infrascrito Jefe del Registro del Estado Familiar identificó al informante por medio de su Cédula de Identidad Personal con número [REDACTED].  
Alcaldía Municipal: Sonsonate, dos de octubre del año mil novecientos ochenta y nueve.

D.Rodri.////O.M.Parada.////, Jefe del Registro del Estado Familiar //// RUBRICADAS ////

Es conforme con su original con la cual se confrontó y para los efectos legales consiguientes se extiende la presente certificación en la Alcaldía Municipal de la ciudad de Sonsonate, a los veintitres días del mes de julio del año dos mil catorce.

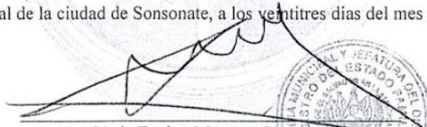
  
Sonia Evelyn Monrroy Vásquez  
Jefe del Registro del Estado Familiar Inta.



# Translated Document



## MUNICIPALITY OF SONSONATE FAMILY STATUS REGISTRY

Landline. (503) 2469-3108, 2469-3100. Fax (503) 2469-3109



The undersigned Head of the Family Status Registry of the Municipality of Sonsonate, CERTIFIES: That on the page one hundred and sixty six of the fifth volume of the book of Births that this institution took in the year nineteen eighty-nine, there is the Certificate that literally reads:

Certificate number one thousand thirty one. [REDACTED], female, was born at nine o'clock on day fourteenth of July of year nineteen eighty-nine, in Sonsonate; being a daughter of [REDACTED] of thirty-one years old, secretary, originally from Santa Ana with domicile in this city, Salvadoran. The information was provided by [REDACTED] [REDACTED], of forty-one years old, Bachelor in Business Administration, originally from Santa Ana with domicile in this city, Salvadoran, who declares to be the father of the newborn and therefore he signs. The undersigned Head of the Family Status Registry identified the informant by means of his Personal Identity Card number [REDACTED] [REDACTED] Municipality of Sonsonate, on day second of October of the year nineteen eighty-nine.

D.Rodri.////O.M.Parada////, Head of the Family Status Registry////INITIALED ////

It is in accordance with its original which was confronted and for the consequent legal effects this certificate is issued at the Municipality of the city of Sonsonate, on the twenty-third day of the month of July of the year two thousand and fourteen.

*Signature*

Sonia Evelyn Monrroy Vásquez  
Head of the Family Status Registry Inta.

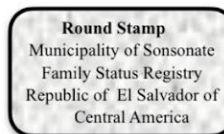

# University Transcript

Original Document

UNIVERSIDAD DE EL SALVADOR

1998



1998

Nº 532021

CINCUENTA CENTAVOS

1	LA INFRASCrita SECRETARIO DE ASUNTOS ACADEMICOS AD-HONOREM, DE LA UNIVERSIDAD			
2	DE EL SALVADOR, CERTIFICA QUE: [REDACTED] CURSO Y APROBADO			
3	EN ESTA UNIVERSIDAD DESDE EL AÑO ACADEMICO 1986-1987, AL AÑO ACADEMICO 1990-1991			
4	LAS ASIGNATURAS ABAJO DETALLADAS SIENDO ACTUALMENTE GRADUADA EN LA CARRERA DE			
5	LICENCIATURA EN QUIMICA Y FARMACIA.-			
6	AÑO ACADEMICO 1986-1987 CICLO I			
7	INGLES I	8.9	OCHO PUNTO NUEVE	APROBADA
8	QUIMICA GENERAL I	8.8	OCHO PUNTO OCHO	APROBADA
9	FISICA I	9.1	NUEVE PUNTO UNO	APROBADA
10	MATEMATICA I	9.4	NUEVE PUNTO CUATRO	APROBADA
11	AÑO ACADEMICO 1986-1987 CICLO II			
12	QUIMICA GENERAL II	8.8	OCHO PUNTO OCHO	APROBADA
13	MATEMATICA II	9.7	NUEVE PUNTO SIETE	APROBADA
14	FISICA II	9.6	NUEVE PUNTO SEIS	APROBADA
15	INGLES II	8.0	OCHO PUNTO CERO	APROBADA
16	TECNICAS DE REDACCION E INVESTIGACION	9.2	NUEVE PUNTO DOS	APROBADA
17	AÑO ACADEMICO 1987-1988 CICLO I			
18	MATEMATICA III	9.2	NUEVE PUNTO DOS	APROBADA
19	QUIMICA INORGANICA I	7.8	SIETE PUNTO OCHO	APROBADA
20	QUIMICA ORGANICA I	8.5	OCHO PUNTO CINCO	APROBADA
21	QUIMICA ANALITICA I	8.1	OCHO PUNTO UNO	APROBADA
22	AÑO ACADEMICO 1987-1988 CICLO II			
23	QUIMICA ORGANICA II	6.5	SEIS PUNTO CINCO	APROBADA
24	QUIMICA ANALITICA II	7.6	SIETE PUNTO SEIS	APROBADA

# Translated Document

UNIVERSITY OF EL SALVADOR

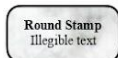

1998



1998

N° 53202

FIFTY CENTS

1	THE UNDERSIGNED AD-HONOREM SECRETARY OF ACADEMIC AFFAIRS OF THE			
2	UNIVERSITY OF EL SALVADOR, CERTIFIES THAT: (NAME OF THE GRADUATE) COMPLETED			
3	AND APPROVED THE COURSES LISTED BELOW AT THIS UNIVERSITY FROM THE ACADEMIC			
4	1986-1987 TO THE ACADEMIC YEAR 1990-1991 AND CURRENTLY GRADUATED OF THE			
5	<b>BACHELOR OF SCIENCE IN CHEMISTRY AND PHARMACY.-</b>			
6	SEMESTER I OF THE ACADEMIC YEAR 1986-1987			
7	ENGLISH I	8.9	EIGHT POINT NINE	PASS
8	GENERAL CHEMISTRY I	8.8	EIGHT POINT EIGHT	PASS
9	PHYSICS I	9.1	NINE POINT ONE	PASS
10	MATHEMATICS I	9.4	NINE POINT FOUR	PASS
11	SEMESTER II OF THE ACADEMIC YEAR 1986-1987			
12	GENERAL CHEMISTRY II	8.8	EIGHT POINT EIGHT	PASS
13	MATHEMATICS II	9.7	NINE POINT SEVEN	PASS
14	PHYSICS II	9.6	NINE POINT SIX	PASS
15	ENGLISH II	8.0	EIGHT POINT ZERO	PASS
16	RESEARCH AND WRITING TECHNIQUES	9.2	NINE POINT TWO	PASS
17	SEMESTER I OF THE ACADEMIC YEAR 1987-1988			
18	MATHEMATICS III	9.2	NINE POINT TWO	PASS
19	INORGANIC CHEMISTRY I	7.8	SEVEN POINT EIGHT	PASS
20	ORGANIC CHEMISTRY I	8.5	EIGHT POINT FIVE	PASS
21	ANALYTICAL CHEMISTRY I	8.1	EIGHT POINT ONE	PASS
22	SEMESTER II OF THE ACADEMIC YEAR 1987-1988			
23	ORGANIC CHEMISTRY II	6.5	SIX POINT FIVE	PASS
24	ANALYTICAL CHEMISTRY II	7.6	SEVEN POINT SIX	PASS

## University Diplomas

Original Document



# University of El Salvador

This Certifies that:

**María Torres**

After completing the studies, and fulfilling the requirements established by the legal and statutory provisions of this University, the graduate has been conferred the Degree of:

**Bachelor in Modern Languages:  
Specialization in French and English**

In a solemn ceremony held today at the University Campus, and in the same ceremony, the graduate has taken the oath of honoring the University under all circumstances with the strict fulfillment with the duties imposed on her by the academic investiture.

Therefore:

This diploma is issued to:

**María Torres**

To enjoy all rights and prerogatives inherent in her capacity of  
**Bachelor of Arts in Modern Languages:  
Specialization in French and English**

of this University, graduated with honors."

Given at the City of San Salvador, capital of the Republic of El Salvador, on the nineteenth day of November in the year of two thousand and twenty"

PRESIDENT OF THE UNIVERSITY

*Signature*

ROGER ARMANDO ARIAS ALVARADO

DEAN OF THE SCHOOL

*Signature*

OSCAR WUILMAN HERRERA RAMOS

SECRETARY-GENERAL

*Signature*

FRANCISCO ANTONIO ALARCÓN SANDOVAL

*Signature*

MARIA TORRES  
GRADUATE





Marriage certificate

Original Document

**Certificate of Marriage**

STATE OF WASHINGTON, }  
County of Chelan } ss. No. 2720

I HEREBY CERTIFY that on the 3<sup>d</sup> day of August  
in the year of our Lord one thousand nine hundred and Nineteen at Penatchee  
in the County of Chelan and State aforesaid, I, the undersigned, a  
Minister of the Gospel by authority of a license bearing date the  
2<sup>d</sup> day of August, A. D. 1919, and issued by the County Auditor  
of Chelan County, did on the 3<sup>d</sup> day of August  
A. D. 1919, join in lawful wedlock [redacted] of the County of  
Chelan State of Washington, and [redacted]  
of the County of Okanogan State of Washington.

In the Presence of

Witnesses  
[redacted] } Robert Warner  
[redacted] } Pastor M. E. Church

Signed [redacted] Groom.  
Signed [redacted] Bride.

NOTE—This Certificate must be returned to the Clerk of the Superior Court of this County within three months from date of Marriage, for record.

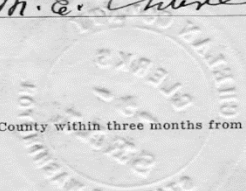

# Partida de Matrimonio

ESTADO DE WASHINGTON,

Condado de *Chelan* } ss

No. 2720

POR LA PRESENTE CERTIFICO QUE: Yo, el infrascrito *Ministro religioso*, por la autoridad que me confiere la licencia para officiar matrimonios con fecha del día 2 de agosto de 1919, y emitida por el Auditor del Condado de *Chelan* el día 3 de agosto de 1919, uní en legítimo matrimonio a *Nombre* originario de *Chelan*, Estado de Washington; y a *Nombre* originaria del Condado de *Okanogan*, Estado de Washington, el día 3 de agosto de mil novecientos *diecinueve*, en *Wenatchee*, Condado de *Chelan*, Estado de Washington.

En presencia de los testigos

Sra. Nombre }

Sr. Nombre }

Firma del Contrayente

*Firma*

Firma de la Contrayente

*Firma*

*Firma*

*Ministro de la Iglesia M.E*

Sello circular inverso grabado en papel  
Secretario  
Frase ilegible  
Condado de Chelan  
Estado de Washington

## 5. CONCLUSIONS

- Translation has been very important since a long time ago. Indeed, almost everyone has been exposed to it and has been in contact with any type of translation all along their lives. For example, movies, books, songs, etc. This has impacted the culture of everyone, and how they interact in order to transmit a message.
- Most people think that someone that speaks another language can translate. This is not true, as speaking a language can be useful when communicating with others, but translation can be a difficult task as it requires a specific knowledge and skills that must be applied when translating a document.
- There are some techniques that can be used in order to provide a natural translation from the source text into the target language. This in order to avoid a literal translation and apply the correct phrases from the language we are translating into.
- Translation is not only an exchange of information in written words, it is more than that. It implies being aware of each culture and language. Therefore, the translator must be involved in this diverse knowledge in order to deliver an accurate job, and also needs to make sure that the reader may not misunderstand the ideas.
- CAT tools are used in order to provide us with better assistance as they support the translation process. These softwares are very useful, as they can help to translate faster and increase the quality of the translation. In addition, they allow the translator to manage and edit the text if needed. Furthermore, they store the information until it is done.
- The translation process is necessary to assure that the source language conveys the same message into the target language. Anyone who translates a document may follow a translation process with the purpose of achieving a high-quality result.
- Translations are not universal as the translation process may vary depending on the translator or agency, since it is adequate according to their requirements taking into account their time and quality implied in the

translation of the document. In addition, the usage of the words depends on each translator, not all of them use the same techniques and tools.

- Not all translators can do a proper translation of any kind of topic. Thus, this means that translators must provide their services according to their field of knowledge in which they are specialized. It is not ethical to translate a document without having a background about its content, as there are some terms used specifically for each area, which the translator may not be aware of. A word in a medical field could mean something very different in another field.
- It is essential to do a proper and deep investigation about the topic that is going to be treated, so the translated text matches the information given in the source text in order to avoid confusion for the reader. Or even more important, to avoid changing the meaning from one language to another.
- People expect translators to do a quick job. This cannot happen without taking the proper time to execute it. Sometimes, it is expected to do an extense translation from one day to another, but this is so far from the reality as translation is a difficult task that cannot be done in limited time. This process may take days, weeks or even months depending on the number of pages the document has.
- It is common to face difficult situations during the translation process where it is hard to reach an agreement, so it can take some time to get opinions together and be in unanimity. Actually, this is part of the process and it is natural to experience those disagreements. In fact, feedback is helpful to improve the overall quality of the translation.

## 6. RECOMMENDATIONS

- Initially, we recommend reading the document as many times as needed to understand the object and the main essence of the content. This is fundamental to create an accurate translation process based on available time and style of work.
- While working as a group in the different projects presented in this portfolio, we recommend doing deep research of the topic and vocabulary. Do not take for granted the meaning, and keep in mind that there are different definitions depending on the context of the text.
- We recommend doing a final revision of the translated document by an external proofreader, in order to make sure of the accuracy of the text. Keep in mind that this person must be fluent in the target language and have an understanding of its culture.
- It is crucial to be loyal to the translation. Do not add or miss information into the target text, unless those changes do not interfere with the essence of the original document. Do not impose or share personal preferences, opinions or ideologies that are not mentioned by the author.
- We advise doing a brief and final review of the translated text to check the company names, name of the clients, numbers, dates, etc. It is necessary to do a side-by-side comparison between both documents, in order to prevent future inconveniences. Try to double check meticulously those details before the delivery of the document.
- Try to use as many resources as you can, also use both physical and virtual dictionaries that are well known and certified. Moreover, make use of translation tools to have a better idea of how to proceed with the translation. Anyhow, do not trust completely in the result they provide, as they will not replace your perception of the context.

## 7. REFERENCES

- *Why is Translation Important in Today's World\_*. (2022, September 14). EMTYIAZ Translation. <https://emtyiaz-translation.com/why-is-translation-important-in-todays-world/>
- Šimurka, M. (2020, November 20). *The importance of translation*. Lexika Translations and Interpretation. <https://www.lexika-translations.com/blog/the-importance-of-translation/>
- Morel, R. (2019, August 12). *Why Do We Need Translation?* Translations and Interpretations. <https://lighthouseonline.com/blog-en/why-do-we-need-translation/>
- Doherty, S. (2016, October). *The Impact of Translation Technologies on the Process and Product of Translation*. International Journal of Communication. <https://ijoc.org/index.php/ijoc/article/viewFile/3499/1573>
- Collins. (n.d.). *Definition of "process."* Retrieved September 25, 2022, from <https://www.collinsdictionary.com/dictionary/english/process>
- Rusdi Noor, R., Silvana Sinar, T., Zubaidah, I.-B., & Setia, E. (2018, November 1). *Pauses by Student and Professional Translators in Translation Process*. International Journal of Comparative Literature & Translation Studies. <http://journals.aiac.org.au/index.php/IJCLTS/article/view/4107>

## 8. ANNEXES

### CERTIFICATION OF ACCURACY

I, **Karla Elizabeth Núñez García**, attest that I am fluent in the **English** language. I have translated the attached of the **Birth Certificate** and that to the best of my knowledge, ability and belief this translation is a true, accurate and complete translation of the original Spanish document that was provided to me.

*Signature*

---

SIGNATURE OF TRANSLATOR

<b>Agency Name</b>	Trad El Salvador
<b>Motto</b>	Traduciendo ideas





<b>Names</b>	<b>Roles</b>
Karla Elizabeth Nuñez Garcia	President
Katherine Gabriela Rosales Aguilar	Translator
Lourdes Marcela Vasquez Ruiz	Translator
Valeria Sarai Mejía Anzora	Proofreaders
Gabriel Eliseo Portillo Garcia	Proofreaders